

## XP Pressure/Suction Product Piping



The 1" size of APT piping can be used in both pressure and suction applications, and are ideal for providing remote feed and fill for heaters, boilers and emergency generators. The 1 1/2", 1 3/4" and 2" sizes of APT product piping can be used in both pressure and suction applications, and are ideal for underground service station fuel delivery systems. The D-series piping is a single wall direct bury piping, while the SC-series piping provides additional environmental security as a secondary contained direct bury pipe. Both feature controlled flexibility, even in low temperatures, permitting fast, easy installation.



### Features & Benefits

#### Feature

- Nylon 12 construction throughout.

#### Benefit

- Time proven material that has been the primary layer of APT pipe for more than 12 years.
- Preferred fuel line material by the world's largest auto makers.
- No polyethylene.

#### Feature

- Layered piping construction of all high grade materials.

#### Benefit

- No possibility of piping layer delamination.

REEL SIZE	INCHES*	CM*
Small Standard	84" x 24" x 64.5"	213.3 x 60.9 x 163.8
Standard (Std.)	86" x 42.5" x 63.5"	218.4 x 107.9 x 161.2
Master	91" x 33" x 74"	231.1 x 83.8 x 187.9
Super Master (S. Mast.)	91" x 52" x 74"	231.1 x 132.1 x 187.9

\*Reel Dia. x Width x Hub Dia.

Do not store piping in direct sunlight.

UL971 listed to the January 2004 standards.

MODEL	DESCRIPTION	FT.	REEL	WEIGHT	
				LBS.	KG.
XP-100-SC-250	1.00" Secondary Contained	250	Small	404	183
XP-100-SC-500		500	Small	516	234
XP-100-SC-2500		2,500	Std.	1,551	704
XP-100-D-250	1.00" Single Wall	250	Small	341	155
XP-100-D-500		500	Small	391	177
XP-150-SC-100	1.50" Secondary Contained	100	Small	346	157
XP-150-SC-250		250	Small	429	194
XP-150-SC-500		500	Small	566	257
XP-150-SC-1000		1,000	Std.	1,000	454
XP-150-SC-1800		1,800	Std.	1,416	642
XP-150-D-100	1.50" Single Wall	100	Std.	1,000	454
XP-150-D-250		250	Small	379	172
XP-150-D-500		500	Small	466	211
XP-150-D-1000		1,000	Std.	760	345
XP-150-D-1800		1,800	Std.	1,056	479
XP-175-SC-100	1.75" Secondary Contained	100	Std.	760	345
XP-175-SC-250		250	Master	454	206
XP-175-SC-500		500	Master	616	279
XP-175-SC-1200		1,200	S. Mast.	1,206	547
XP-175-D-100		1.75" Single Wall	100	Master	326
XP-175-D-250	250		Master	379	172
XP-175-D-500	500		Master	466	211
XP-175-D-1500	1,500		S. Mast.	951	431
XP-200-SC-100	2.00" Secondary Contained		100	Master	632
XP-200-SC-200		200	Master	742	337
XP-200-SC-350		350	Master	907	411
XP-200-SC-700		700	S. Mast.	1,490	676
XP-200-D-100		2.00" Single Wall	100	Master	597
XP-200-D-200	200		Master	672	305
XP-200-D-350	350		Master	785	356
XP-200-D-700	700		S. Mast.	1,245	565





## XP Pressure/Suction Product Piping

### XP Piping Construction

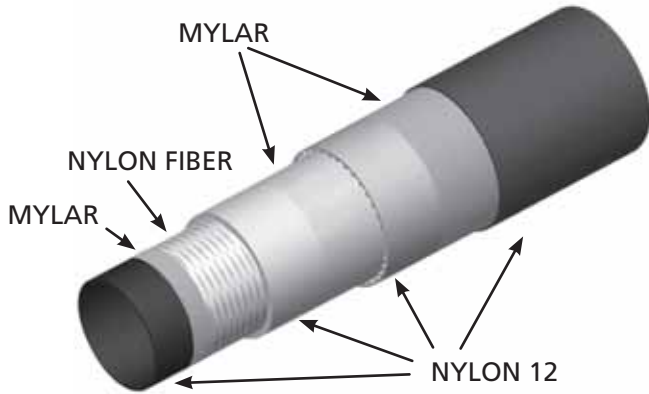

### XP Piping Dimensions

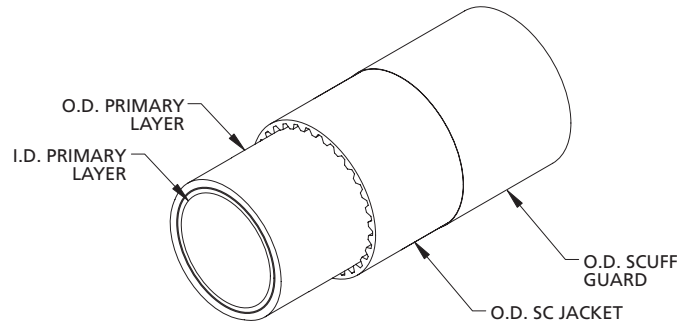

### APT Pressure/Suction Pipe

MODEL	I.D. $\pm 0.010$ PRIMARY LAYER	O.D. $\pm 0.020$ PRIMARY LAYER	O.D. $\pm 0.030$ SC JACKET	O.D. $\pm 0.030$ SCUFF GUARD	MINIMUM BEND RADIUS
XP-100-D	1.000	1.270	N/A	N/A	36.00"
XP-100-SC	1.000	1.270	1.470	1.502	36.00"
XP-150-D	1.400	1.700	N/A	N/A	36.00"
XP-150-SC	1.400	1.700	1.900	1.925	36.00"
XP-175-D	1.650	1.950	N/A	N/A	36.00"
XP-175-SC	1.650	1.950	2.150	2.175	36.00"
XP-200-D	2.040	2.450	N/A	N/A	36.00"
XP-200-SC	2.040	2.450	2.650	2.675	36.00"