

Medium-Pressure Portable Pump

Description

The major components of the portable pump assembly in the 9961 model series consist of a(n):

- air-operated motor
- double-acting reciprocating pump tube
- drum cover assembly
- drum dolly assembly
- control valve assembly with delivery hose
- electronic meter

Pump Assembly

The medium-pressure (5:1 ratio) pump included with the assembly is designed to deliver gear oils directly from original 16-gallon containers.

Models 9961-1 and 9961-A1

The electronic meter on each model registers in a different unit of measurement. See **Figure 1**.

NOTE: Both portable pump models contain a 9968-A stripped pump.

Specifications

IMPORTANT: For detailed information on the pump tube (including specifications and performance data) refer to SER 9968.

For information on the motor, please refer to SER 339413.

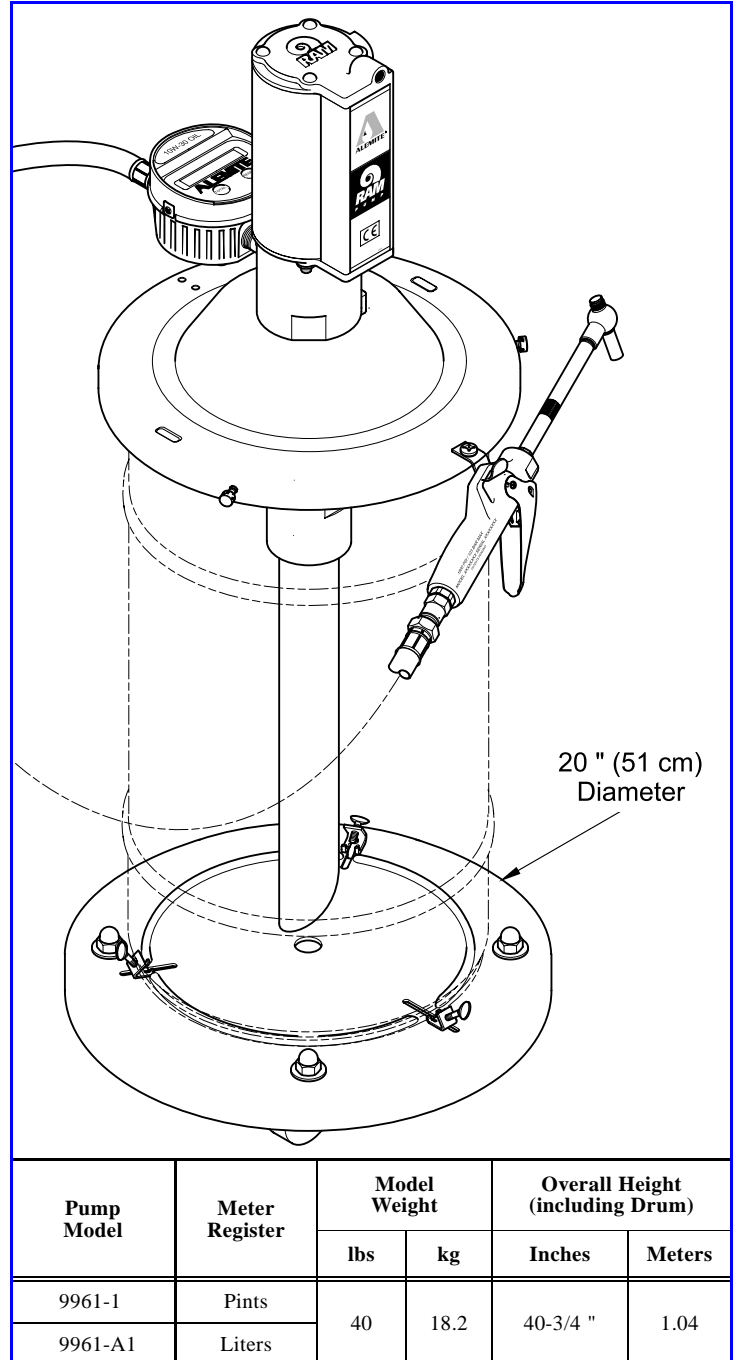

Figure 1 Medium-Pressure Portable Pump
Models 9961-1 and 9961-A1

Item No.	Part No.	Description	Qty	Pump Model		Notes	Numeric Order Part # (Item #)		
				9961-1	9961-A1				
1	9968-A	Pump Assembly	1	Both		See SER 9968	3630-A (4)		
2	338147-1	Extension, 21-3/4 " Long	1					3631 (4)	
3		Nipple, 1/2 " NPTF (m)	1					9968-A (1)	
4	3631	Meter, Electronic (Pints)	1	●		See SER 3630	7492 (14)		
	3630-A	Meter, Electronic (Liters)	1				●	17804 (10)	
5	317813-5F	Hose, Material, 1/2 " ID (5-1/2 ' Long)	1	Both			48018 (7)		
6	338145	Cover Assembly (w/ Gasket)	1					77009 (16)	
7	48018	Screw, Thumb, 1/4 " -28	3				Included with item 6	77650 (15)	
8		Capscrew, 1/4 " -20 x 1/2 "	4					77786 (8)	
9		Washer, Lock, 1/4 "	4					170343 (13)	
10		Washer, 1/4 "	4					172207-1 (9)	
11	316315-5	Dolly Assembly	1				See SER 316315-5	172263-4 (3)	
12		Hanger	1				◇	316315-5 (11)	
13		Screw, 1/4 " -20 x 7/16 "	1				◇	317813-5F (5)	
14	7492	Valve Assembly, Control	1				See SER 7492	338147-1 (2)	
15		Nut, Hex Head, 1/4 " -20	1				◇	338145 (6)	
16		Washer, Lock, 1/4 "	1				◇	338788 (12)	
Legend: Part numbers left blank (or in <i>italics</i>) are not available separately ◇ designates a repair kit item									

Repair Kit

Part No.	Kit Symbol	Description
393663	◇	Kit, Hanger Assembly

Assembly

NOTE: Refer to **Figure 2** for component identification on all assembly procedures.

CAUTION

Select a clean environment for all assembly procedures. Prevent contamination from foreign material. Damage to components can occur.

Dolly

1. Secure the container to Dolly (8).
 - Refer to SER 316315-5 for details.

Pump Assembly

IMPORTANT: Make sure to remove the protective cover from the inlet of Pump Assembly (1).

Do not apply thread sealant to the first two (2) threads of any connection. Contamination can occur.

2. Install the Pump and Extension Assembly into Cover (6).
3. Secure the Pump Assembly to the Cover with Washers (16), Lock Washers (15), and Capscrews (14).
 - Tighten the Capscrews securely in a crisscross pattern.
4. Fit the pump and cover assembly onto the container.
5. Secure the Cover to the container with Thumb Screws (7).

Control Valve and Material Hose

6. Screw the Control Valve and Hose Assembly (with thread sealant) into Meter (4).
 - Tighten the Hose securely.
7. Attach the Control Valve onto Hanger (9).

Changes Since Last Printing

Deleted Connector and Coupler from Air Motor