

High-Pressure Stationary Pump

Description

The major components of the high-pressure stationary pump assembly model 9979-A consist of a(n):

- air-operated motor
- double-acting reciprocating pump tube
- cover assembly
- follower plate

Pump Assembly

The high-pressure (50:1 ratio) pump included with the assembly is designed to deliver a range of greases directly from a 400-pound container.

Follower Plate

The follower plate is designed with a flexible edge that allows operation in tapered containers.

Specifications

IMPORTANT: For detailed information on the pump tube (including specifications and performance data) refer to SER 9930.

For information on the motor, please refer to SER 339413.

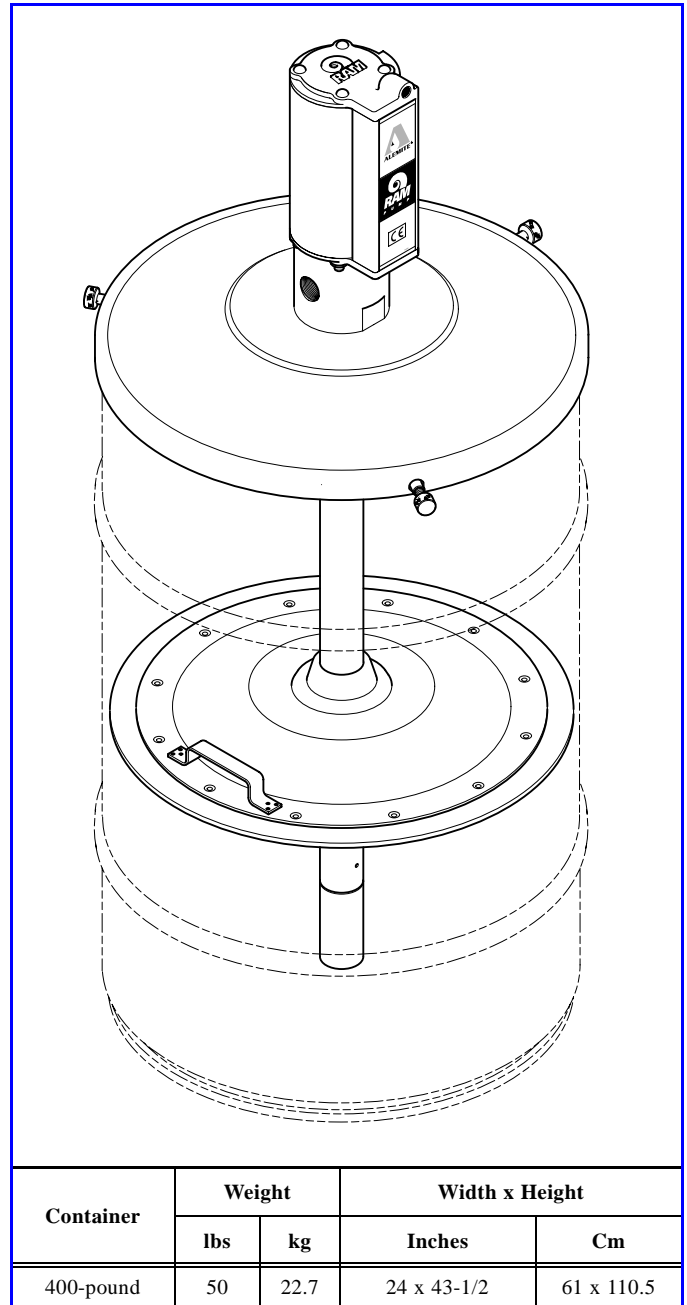
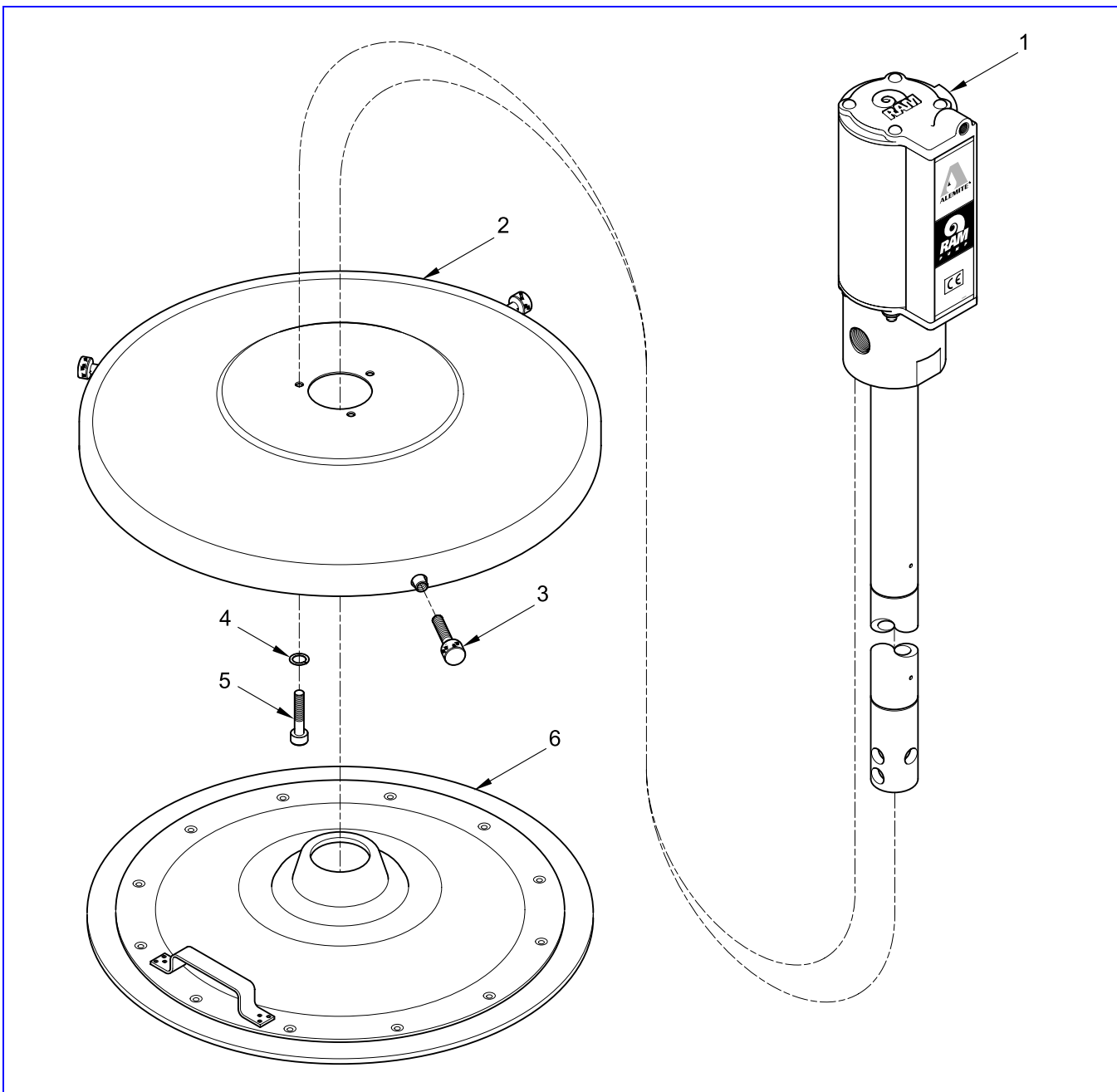

Figure 1 High-Pressure Stationary Pump
Model 9979-A

Alemite Corporation
PO Box 473515, Charlotte, North Carolina 28247-3515
www.alemite.com

Copyright © 2000 by Alemite Corporation



Item No.	Part No.	Description	Qty	Notes	Numeric Order Part # (Item #)
1	9979	Pump Assembly, High-Pressure	1	See SER 9930	9979 (1)
2	338165	Cover Assembly	1		48018 (3)
3	48018	Screw, Thumb	3		77786 (5)
4	172207-1	Washer, Lock, 1/4 "	3		172207-1 (4)
5	77786	Screw, 1/4 " -20 x 1/2 "	3		338165 (2)
6	338911	Plate, Follower	1		338911 (6)

Legend:

Part numbers left blank (or in *italics*) are not available separately

Figure 2 High-Pressure Stationary Pump Model 9979-A - Exploded View

Assembly

NOTE: Refer to **Figure 2** for component identification on all assembly procedures.

CAUTION

Select a clean environment for all assembly procedures. Prevent contamination from foreign material. Damage to components can occur.

Pump Assembly

IMPORTANT: Make sure to remove the protective cover from the inlet of Pump Assembly (1).

1. Install Pump Assembly (1) into Cover (2).
 - Make sure to align the Screw holes.
2. Secure the Pump Assembly to the Cover with Lock Washers (4) and Screws (5).
 - Tighten the Screws securely.

Follower Plate

3. Place Follower Plate (6) onto the top of the product.
 - With a wobbling motion, eliminate any air that may be trapped underneath the Follower Plate. Force the product through the hole in the center of the Plate.
4. Guide the pump tube into the Follower Plate and fit the Cover onto the container.
5. Secure the Cover to the container with Thumb Screws (3).
6. Test/Prime the Pump assembly.
 - Refer to Service Guide SER 9630 for details.

Changes Since Last Printing

Deleted Connector and Coupler from Air Motor

