

800 HYDROGLASS

For Water Detection & Particulate Removal



Cim-Tek® Filtration

Bio-Tek®

Renewable Fuels Technology

MODEL: 800BHG

Application

- Water detection and particulate removal for Ethanol-blended gasoline up to E20 and Biodiesel blends up to B20
- Extended life filter for high-volume renewable fuel dispensing
- For use at high-capacity commercial fueling centers
- Specifically designed for bio-fuel filtration

Design Features

- 40 gpm (151 lpm) maximum flow
- 50 psi (3.4 bar) maximum working pressure
- 2 micron and 10 micron media compatible with bio-fuels
- 2 micron media utilizes Progressive Density® Hydroglass media
- Pre-Lubed Gaskets standard



800BHG w/Dual Adaptor

Benefits

- High performance media compatible with aggressive solvent nature of bio-fuels
- Removes common particulate contaminants at high-flow rates
- Recognized by the Underwriter's Laboratory (UL®) for use with service station pumps and dispensers
- Extended length provides higher dirt-holding capacity
- Ease of installation with Pre-Lubed Gaskets

800 Bio-Tek® Hydroglass Series Dimensional Information

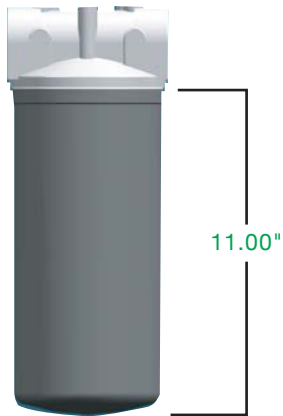

800BHG w/Aluminum Adaptor

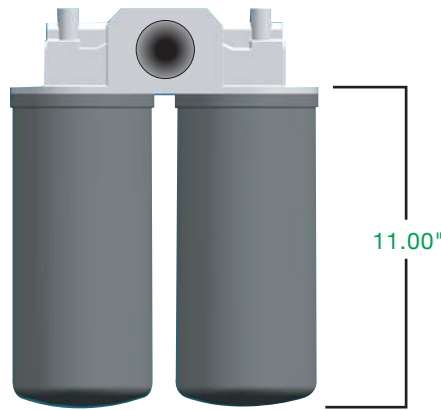

800BHG w/Double Aluminum Adaptor

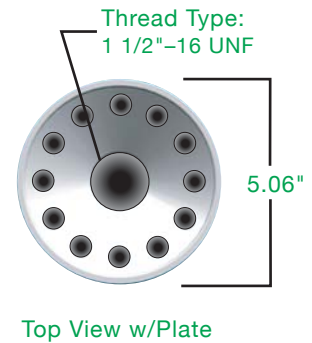

Top View w/Plate

Ordering Information

Part No.	Model No.	Description
70037	800BHG-02	High-Volume Commercial Particulate Removal Spin-On Filter for Ethanol Blends up to E20 and Biodiesel up to B20. 2 Micron Progressive Density® Hydroglass Media. (1 1/2"-16 UNF Thread)
70024	800BHG-10	High-Volume Commercial Particulate Removal Spin-On Filter for Ethanol Blends up to E20 and Biodiesel up to B20. 10 Micron High Performance Hydroglass Media. (1 1/2"-16 UNF Thread)

Adaptors

Part No.	Model No.	Description	Fuel Ports	Nose	Use With
50109	805	Single Aluminum Adaptor	1" NPT	1 1/2"-16 UNF	All Above
50026	805GP	Single Aluminum Adaptor w/Gauge Ports-1/8" NPT	1" NPT	1 1/2"-16 UNF	All Above
50163	810	Single Aluminum Adaptor	1 1/2" NPT	1 1/2"-16 UNF	All Above
50011	820	Double Aluminum Adaptor	2" NPT	1 1/2"-16 UNF	All Above
50027	810GP	Single Aluminum Adaptor w/Gauge Ports-1/8" NPT	1 1/2" NPT	1 1/2"-16 UNF	All Above
50028	820GP	Double Aluminum Adaptor w/Gauge Ports-1/8" NPT	2" NPT	1 1/2"-16 UNF	All Above

NOTE: See adaptor page for additional details.

Replacement Gasket

Part No.	Description
90041	Buna-N Pre-Lubed Gasket Used On All Above

NOTE: Filters are not to be used with aviation applications.

COURTESY OF

MASCOTT EQUIPMENT COMPANY

Portland Seattle Tri-Cities

www.mascottec.com

10.16

REVISED 11/05