



FE PETRO[®]

Franklin Fueling Systems

High Capacity Submerged Turbine Pumps

Installation and Owner's Manual







50 Hz/60 Hz Models STP-3 and STP-5

COURTESY OF
MASCOTT EQUIPMENT COMPANY
Portland Seattle Tri-Cities
www.mascottec.com

Important Safety Messages

FE Petro equipment is designed to be installed in association with volatile hydrocarbon liquids such as gasoline and diesel fuel. Installing or working on this equipment means working in an environment in which these highly flammable liquids may be present. **Working in such a hazardous environment presents a risk of severe injury or death if these instructions and standard industry practices are not followed. Read and follow all instructions thoroughly before installing or working on this, or any other related equipment.**

As you read this guide, please be aware of the following symbols and their meanings:

- Warning**  This symbol identifies a warning. A warning sign will appear in the text of this document when a potentially hazardous situation may arise if the instructions that follow are not adhered to closely. A potentially hazardous situation may involve the possibility of severe bodily harm or even death.
- Caution**  This is a caution symbol. A caution sign will appear in the text of this document when a potentially hazardous environmental situation may arise if the instructions that follow are not adhered to closely. A potentially hazardous environmental situation may involve the leakage of fuel from equipment that could severely harm the environment.
-
- Warning**  **Follow all applicable codes governing the installation and servicing of this product and the entire system. Always lock out and tag electrical circuit breakers while installing or servicing this equipment and related equipment. A potentially lethal electrical shock hazard and the possibility of an explosion or fire from a spark can result if the electrical circuit breakers are accidentally turned on during installation or servicing. Do not smoke while working on or near this equipment, and use only non-sparking tools.**
- Warning**  **Before entering a containment sump, check for the presence of hydrocarbon vapors. If these vapors are inhaled they could cause dizziness or unconsciousness, and, if ignited, hydrocarbon vapors could explode causing serious injury or death. Electronic and electrical petroleum monitoring equipment is often housed in containment sumps designed to trap hazardous liquid spills and prevent contamination of the environment, and, as a consequence, containment sumps can trap dangerous amounts of hydrocarbon vapors. If these vapor levels reach unsafe amounts, ventilate the sump with fresh air. While working in the sump, periodically check the atmosphere in the sump, if vapors reach unsafe levels, exit the sump and ventilate it before continuing work. Always have a second person standing by for assistance when working in, or around, a containment sump.**
- Warning**  **Follow all federal, state, and local laws governing the installation of this product and its associated systems. When no other regulations apply, follow NFPA codes 30, 30A, and 70 from the National Fire Protection Association. Failure to follow these codes could result in severe injury, death, serious property damage, and/or environmental contamination.**
- Warning**  **Always secure the work area from moving vehicles. The equipment in this manual is usually mounted underground, so reduced visibility puts service personnel working on this equipment in danger from moving vehicles entering the work area. To help eliminate these unsafe conditions, secure the area by using a service truck to block access to the work environment, or by using any other reasonable means available to ensure the safety of service personnel.**
- Warning**  **Thermal expansion can cause pressure to build up in the product lines. FE Petro STPs have a built-in relief valve to release this excess line pressure back to the tank. Do not use an additional check valve unless it has the capability to relieve excess pressure back to the tank, as this could result in a buildup of abnormal pressure in the lines, causing a pipe or joint in the supply line piping to burst, and release of fuel into the environment.**

Note: Some underground storage tanks are ballasted with water during construction. DO NOT use the submersible pump to remove water from the tank. The pump is designed for use with petroleum products only, and pumping other fluids will seriously damage the unit. We do not recommend immersing the pump in water, but if this does happen immediately fill the tank with motor fuel after the water is removed from the tank. Severe corrosion takes place very quickly if the unit has been submerged in water and is then exposed to air.

Note: Installing submerged fill pipes in the same manway cover as the submersible pump has been known to cause “air locking” of the submersible when the pump is operating during tank filling. Therefore, FE Petro does not recommend this practice.

Installer: This instruction booklet MUST be left with the owner of the service station at which the equipment is being installed.

Station Owner: Retain these instructions for future use and provide them to persons servicing or removing this equipment.

Installation Instructions

The piping and underground storage tank must be installed using good standard industry practices. There are several publications which can be used for reference, some of which are:

- A. Automotive and Marine Service Station Code, NFPA 30A, Flammable and Combustible Code, NFPA 30, and National Electrical Code, NFPA 70 (NEC), National Fire Protection Association, Quincy, Mass.
- B. Recommended Practices for Installation of Underground Liquid Storage Systems, The Petroleum Equipment Institute, PEI/RP100, Latest Edition.
- C. Recommended Practices for Installation of Aboveground Storage Systems for Motor Vehicle Fueling, The Petroleum Equipment Institute, PEI/RP200, Latest Edition.
- D. Installation of Underground Petroleum Storage Systems, American Petroleum Institute, API Recommended Practice 1615, Latest Edition.

Preparation

1. Disconnect power for the submersible pump at the electrical supply box (if already installed).
2. Tag and lock out electrical circuit breakers so they are not turned on accidentally.

Warning  **If the electrical circuit breakers are accidentally turned on while the STP is being installed, electrical power could be applied to the STP, creating a dangerous and potentially lethal electrical shock hazard for personnel, as well as creating the possibility of a spark which could ignite hydrocarbon vapors present during STP installation. ALWAYS tag and lock breakers so they are not turned on accidentally.**

3. Remove the top from the shipping crate. (Fig. 1) Measure the pump, from the bottom of the threaded riser to the bottom of the pump-motor, and compare this to the tank measurement, measured from the mounting flange to the inside of tank bottom. The STP and riser are sized to place the intake (at the bottom of the pump-motor) approximately 5 inches off the bottom of the tank. If the difference between the bottom of the pump motor and the bottom of the tank is more than 6 inches or less than 4 inches, verify that this is the correct pump for this tank installation. If it is not the correct pump and is outside the above specifications, contact FE Petro for assistance.

Warning  **Do not modify this pump in the field. FE Petro submerged turbine pumps are subjected to rigorous quality control testing during assembly. Field alteration of the pumps in any way, including shortening of the column pipe and conduit, defeats these quality tests, and could result in a fuel leak or dangerous electrical contact.**

4. Apply a non-hardening, UL listed, gasoline-resistant pipe sealing compound to the riser pipe threads.

Warning  **Failure to use a proper thread sealing compound could result in a lack of sealing where the riser threads into the tank opening, making it impossible to perform a tank-tightness test. This could also create a potential site for fuel to leak into the environment and/or the containment sump.**

5. Using a hoist, raise the unit from the crate to the vertical position. Do not drop or rest the unit on the bottom end bell of the pump motor assembly.

Note: The bottom end-bell of the pump-motor assembly is not designed to support the weight of the entire STP. Resting or dropping the STP on the end bell may damage the end bell and the pump components inside. This type of damage is not considered a manufacturing defect under the FE Petro warranty.

6. (Fig. 1) Carefully lower the unit into the tank, and engage the threaded riser of the pump into the threaded flange of the tank. Tighten the riser into the tank using a large pipe wrench until a liquid/air tight joint has been made. Accomplish this by turning in the tightening (clockwise) direction only.

Caution  **Turning the pump in the loosening direction during the tightening process may scrape away the thread sealing compound, making it difficult or impossible to obtain a liquid/air tight seal.**

- (Fig. 1) Connect the supply line piping to the discharge port or ports in the manifold assembly. The discharge ports are dual (180° opposed) 3-inch NPT horizontal openings.

Warning  **If only one of the manifold discharge ports is used, plug the opposite port with an approved 3-inch pipe plug. Apply a non-hardening, UL listed, gasoline resistant pipe sealing compound to the pipe plug threads prior to installation into discharge port. Failure to use proper thread sealing compound could result in a lack of sealing, creating a potential site for fuel leakage into the containment sump and/or environment.**

- (Fig. 2) Remove compression water seal, bushing rings, and tag attached to the manifold. Feed wires supplied with STP through a bushing ring and the seal and install as shown on tag at the 1-inch NPT horizontal opening. Install the other bushing ring and a 1" NPT pipe nipple behind the compression water seal to compress and achieve sealing in the opening.

Warning  **All electrical equipment, wiring, and related installation should be in accordance with applicable federal, state, and local codes and/or applicable NFPA and National Electrical Codes (NEC). The compression seal is not intended to replace the vapor explosion seals required by the NEC. All materials used between the power supply box and the STP must be gasoline and oil resistant. Failure to comply with these, and all applicable NEC guidelines, could result in an unsafe installation.**

Note: FE Petro will not be responsible for damage to electrical units resulting from improper installation of the compression seal.

Note: A length of wire has been supplied from the factory beyond the compression seal for the purpose of field wiring to an external explosion proof junction box prior to the explosion seals. Check applicable federal, state, and local codes for usage and location requirements of such a junction box.

- Verify that the power is still OFF at the supply box and locked out. (Fig. 3) Pull the field wiring from the STP to the control panel.

Note: Color code between the control panel and STP must be accurately followed to prevent power circuit (black, orange, and red leads) from being applied to the thermal overload circuit (two blue leads). If the color code is not maintained, serious damage may result to control panel or motor for which FE Petro will not be responsible.

Note: Steps 10 through 13 describe the wiring of an FE Petro supplied STP-CB 3 or 5 control panel. If the control panel is not an FE Petro supplied control panel, contact control panel manufacturer for installation recommendations and verify control panel specifications for ambient compensation, 3-leg protection, and quick trip heaters before usage. If using the FE Petro three phase Smart controller (STP-SCIII) refer to the STP-SCIII Installation and Owner's manual for complete installation instructions.

- (Fig. 3) Prepare STP-CB 3 or 5 control panel for wiring by removing factory jumper between terminal 3 (below L2) and terminal X2 (adjacent to T1), if present.

Note: If the jumper is not removed, thermal overload circuits will not function and serious electrical damage may occur to the motor circuitry if an overload condition should occur.

- (Fig. 3) Connect the five motor leads from the STP to the following control panel terminals: motor black to terminal T1, motor orange to terminal T2, motor red to terminal T3, one motor blue to terminal X2, and the other motor blue must be connected into one leg of the voltage source at the control switch to energize the starter from the dispensers (the other leg of the control switch wiring from the dispensers is to be connected into terminal 3 as shown in the figure).

Note: The motor blue wires control the thermal overload inside the motor, and do not necessarily have to connect to a specific terminal location, as long as one wire is connected to each terminal location specified in step 11.

Note: The thermal overload relay in the control panel is delivered with heaters already installed for the horsepower/service of the submersible pump model for which it was ordered. If the incorrect heaters are installed, the overload circuit may not function properly. Verify that the correct heaters are installed in the control panel for your submersible pump model (Fig. 3).

- (Fig. 3) Connect the motor green to chassis ground inside the control panel. Connect the power lines from the power supply box to the control panel terminals marked L1, L2, and L3.

Warning  **Be certain the pump-motor assembly, discharge and conduit piping, and whatever control components used are grounded before energizing the system. Shock hazards can be created, and damage to equipment may result if this is not done properly. Check line voltage to be sure it falls within the volts required for these motors as specified on the STP nameplate.**

Note: The STP is delivered with the motor green ground wire from the factory. We strongly recommend the use of the ground wire. However, some federal, state, and local codes may allow the wiring of submersibles without a ground.

13. Verify the power for the submersible pump at the electrical supply box is tagged and the electrical circuit breakers are locked out so they are not turned on accidentally.

Warning  **If the electrical circuit breakers are accidentally turned on while the STP is being installed, electrical power could be applied to the STP, creating a dangerous and potentially lethal electrical shock hazard for personnel, as well as creating the possibility of a spark which could ignite hydrocarbon vapors present during STP installation. ALWAYS tag and lock out breakers so they are not turned on accidentally.**

14. (Fig. 4) Remove the pipe plug in the pressure port (upper port of the syphon loop connection) and install a 0-60 psi pressure gauge and a valve to relieve line pressure.

Caution  **When opening the submersible pump or piping system, always make adequate provisions to trap the liquid that escapes to prevent contamination of the environment.**

15. Energize the STP and note the reading at the pressure gauge. De-energize the STP at the power supply box and swap wires at terminals T1 and T2. Relieve line pressure to zero, energize the STP, and again note the reading at the pressure gauge. The arrangement of these two wires which gave the highest pressure reading, is the correct arrangement for proper motor rotation. Again disconnect power for the STP to remove the pressure gauge and reinstall the pipe plug using thread sealing compound. Refer to Table 1 (page 9) for proper STP operating pressures.

Warning  **If the electrical circuit breakers are accidentally turned on while the STP is being installed, electrical power could be applied to the STP, creating a dangerous and potentially lethal electrical shock hazard for personnel, as well as creating the possibility of a spark which could ignite hydrocarbon vapors present during STP installation. ALWAYS tag and lock out breakers so they are not turned on accidentally.**

Warning  **Failure to use a proper thread sealing compound could result in a lack of sealing where the plug threads into the manifold, creating a potential site for fuel to leak into the environment and/or the containment sump.**

16. Purge system of air by dispensing product at all fueling locations, starting at the farthest away and working your way back to the STP.

Caution  **Upon startup and routinely thereafter under federal, state, and local standards, a precision line test must be conducted to assure line integrity.**

Caution  **Be certain that fuel has been placed in the tank before attempting to run the STP. Running a unit in a totally dry condition, such as that with a new installation where fuel has yet been placed in the tank, may result in extensive damage to the pump and motor before sufficient heat can be transferred to the thermal overload protector circuits. FE Petro will not be responsible for such damage.**

Additional Information: For additional copies of these Installation Instructions, contact FE Petro.

Pump Motor Assembly (PMA) Replacement: For instructions for replacing a pump-motor assembly, see Figure 9.

Replacement Parts: For replacement parts breakdown of the STP and Syphon Unit, see Figures 7 and 8.

Note: If STP does not operate correctly or there are any questions concerning installation or service, contact FE Petro Technical Service at (800) 225-9787.

Syphon Systems: (Optional) (Fig. 4, 5, 6 & 8) Some jurisdictions allow two or more tanks of the same product grade to be manifolded together with a syphon loop line. These systems usually have a single submersible pump, and the syphoning action keeps the tanks level while pumping out of only one tank. All FE Petro submersible pumps have the syphoning capability with the attachment of a syphon unit manufactured by FE Petro. The syphon unit incorporates a syphon check valve, see Figure 4 and 8. The outlet of the syphon unit should be connected with a line to the highest spot in the syphon loop line.

When correctly installed, the syphon action between the tanks will continue whether the pump is running or not, as long as the product level in the tanks is higher than the bottom of the syphon loop line vertical piping. The function of the STP in the syphon system is merely to prime the syphon line, removing the air and allowing the syphon to take place. The pump creates a syphon with a vacuum of approximately 20-28" Hg on the outlet of the syphon unit. Tanks should be of the same diameter and should be on the same plane when a syphon loop is used. When not possible, tanks of different diameters can be used but complications may arise.

Line Leak Detectors: If you are using a Mechanical Leak Detector with a vapor vent, the vapor can be returned to the tank through the ¼" Tank Port on the pump manifold (Fig. 1). If a syphon is also being used, remove the plug from the tee in Figure 4. All equipment must be installed per manufacturer installation specifications.

Electrical Motor Data and Operation Specifications: Table 1 lists the electrical data for all High Capacity Submerged Turbine Pump Models. This information can be helpful for power supply, wiring, and fuse sizing, or troubleshooting.

<u>Model</u>	<u>Voltage rating</u>	<u>Operating Pressure (PSI)</u>	<u>Max. Amps</u>	<u>Locked Rotor Amps</u>	<u>Lead to Lead Resistance</u>
STP 3 (D)	208/230 V, 60Hz	33	11	63	2
STP 5 (D)	208/230 V, 60Hz	40	17.2	91	1
STP 3 C	380-415 V, 50Hz	36	5.4	29	8
STP 5 C	380-415 V, 50Hz	42	8.7	49	4
STP 5 G	575 V, 60Hz	40	6.9	36	6
STP 5 H	460 V, 60Hz	40	8.6	52	4

Warning  **STP pumps are designed for motor fuels, and are UL listed for blend concentrations of:**

Standard Models	AG (Alcohol/Gasoline) Models
0% - 15% ethanol or methanol and gasoline	0% - 15% ethanol or methanol and gasoline
20% MTBE with 80% gasoline	20% MTBE with 80% gasoline
20% ETBE with 80% gasoline	20% ETBE with 80% gasoline
17% TAME with 83% gasoline	17% TAME with 83% gasoline

Other motor fuels that may be used with the STP are Diesel, Fuel Oil, Avgas, Jet Fuel, or Kerosene. The maximum liquid viscosity for a product is 70 S.S.U. at 60° F.

Using our STP pumps in liquids other than those mentioned above has not been tested. The reaction of other liquids with seals and wetted surfaces of the pump is unknown. A hazardous situation may result from using other liquids with our pump.

Installation Notes

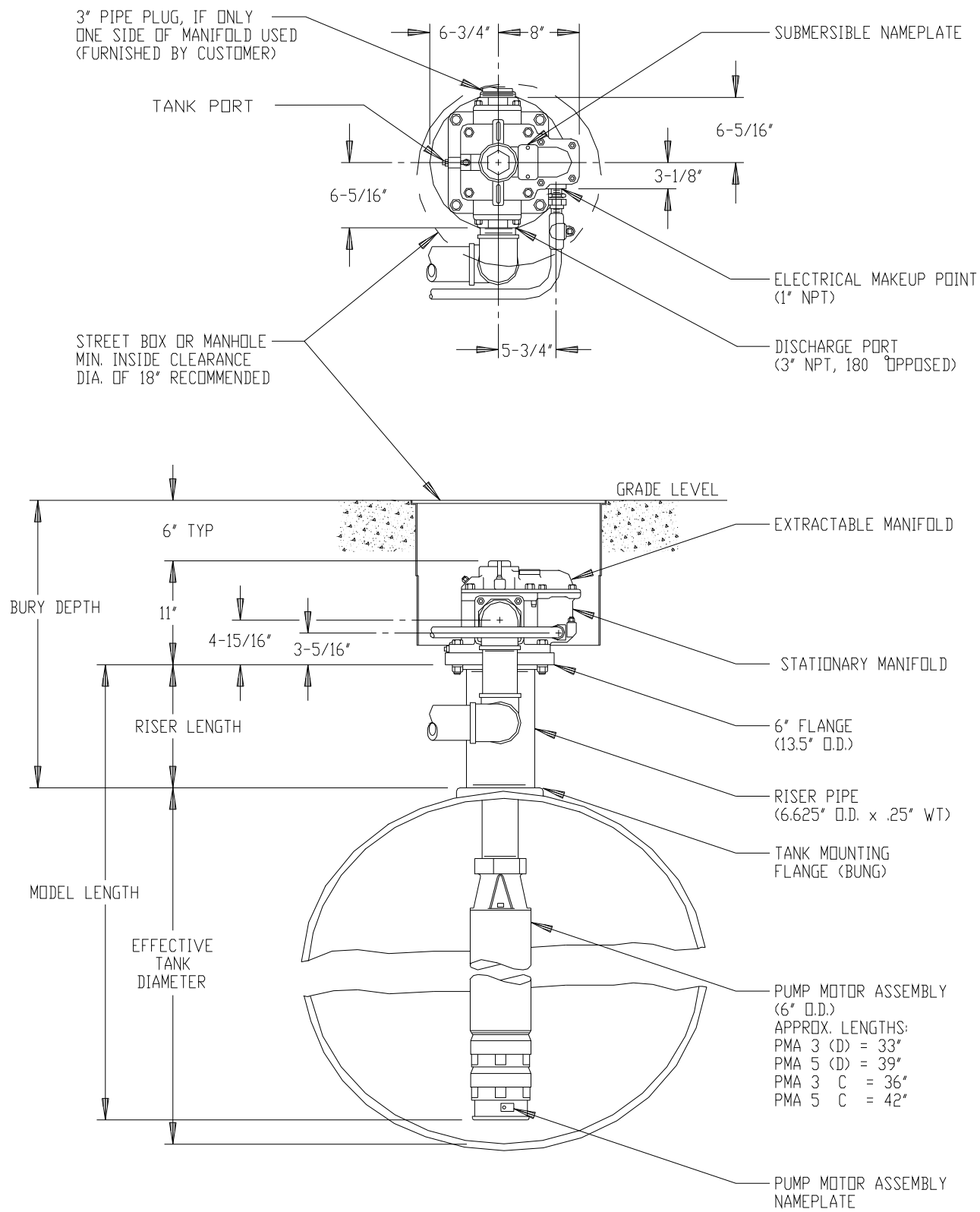
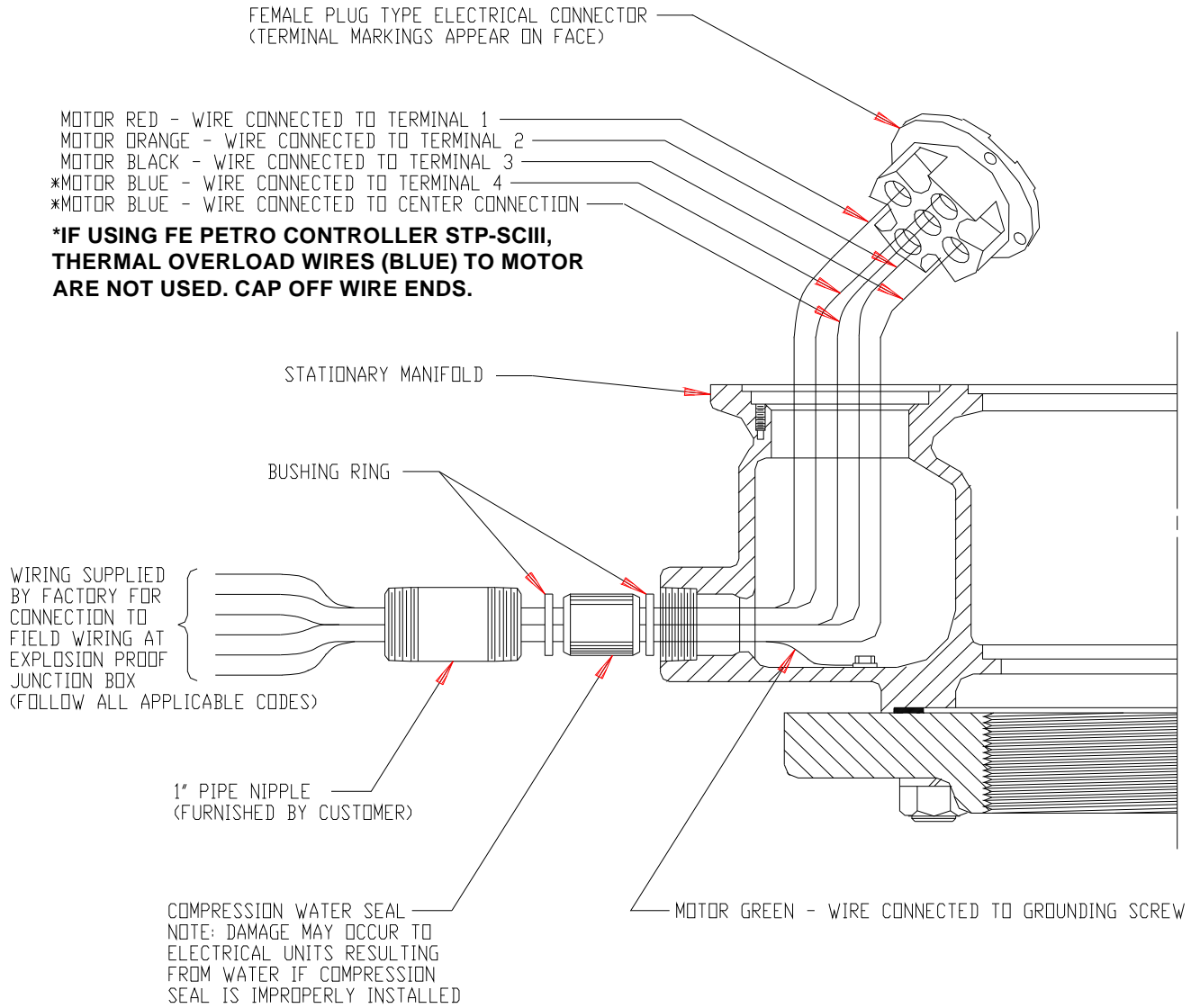

FIGURE 1

REV. D



NOTE: COLOR CODE BETWEEN CONTROL PANEL AND STP MUST BE ACCURATELY FOLLOWED TO PREVENT POWER CIRCUIT (BLACK, ORANGE, AND RED LEADS) FROM BEING APPLIED TO THE THERMAL OVERLOAD CIRCUIT (BLUE LEADS) IF COLOR CODE IS NOT MAINTAINED, SERIOUS DAMAGE MAY RESULT TO CONTROL PANEL OR MOTOR.

FIGURE 2

WIRING DIAGRAM FOR STP-CB3/5 (115V coil) AND STP-CBB3/5 (240V coil)

3 PHASE MOTOR CONTROL PANEL WIRING DIAGRAM (FOR NON-HAZARDOUS, INDOOR USE ONLY)

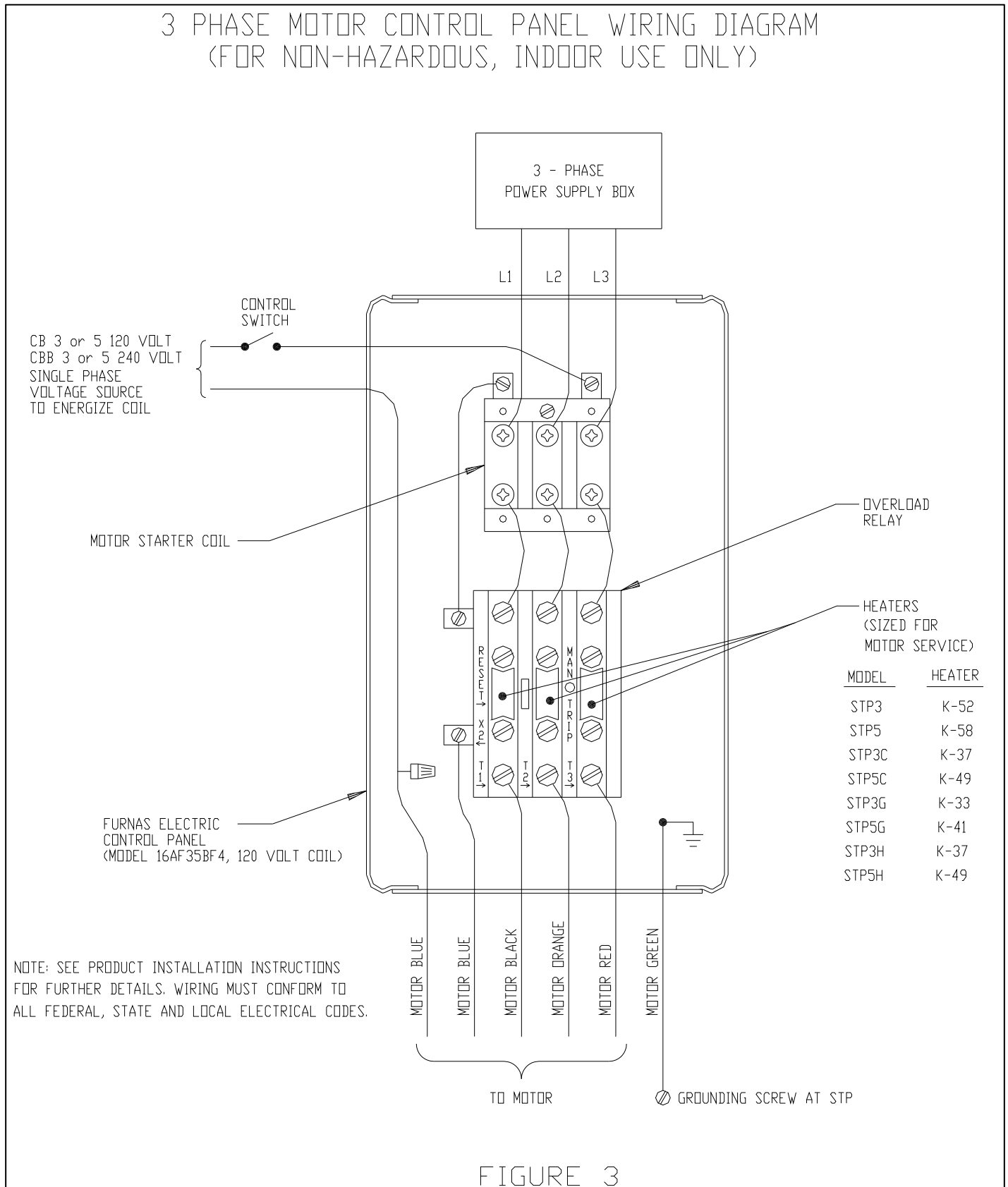
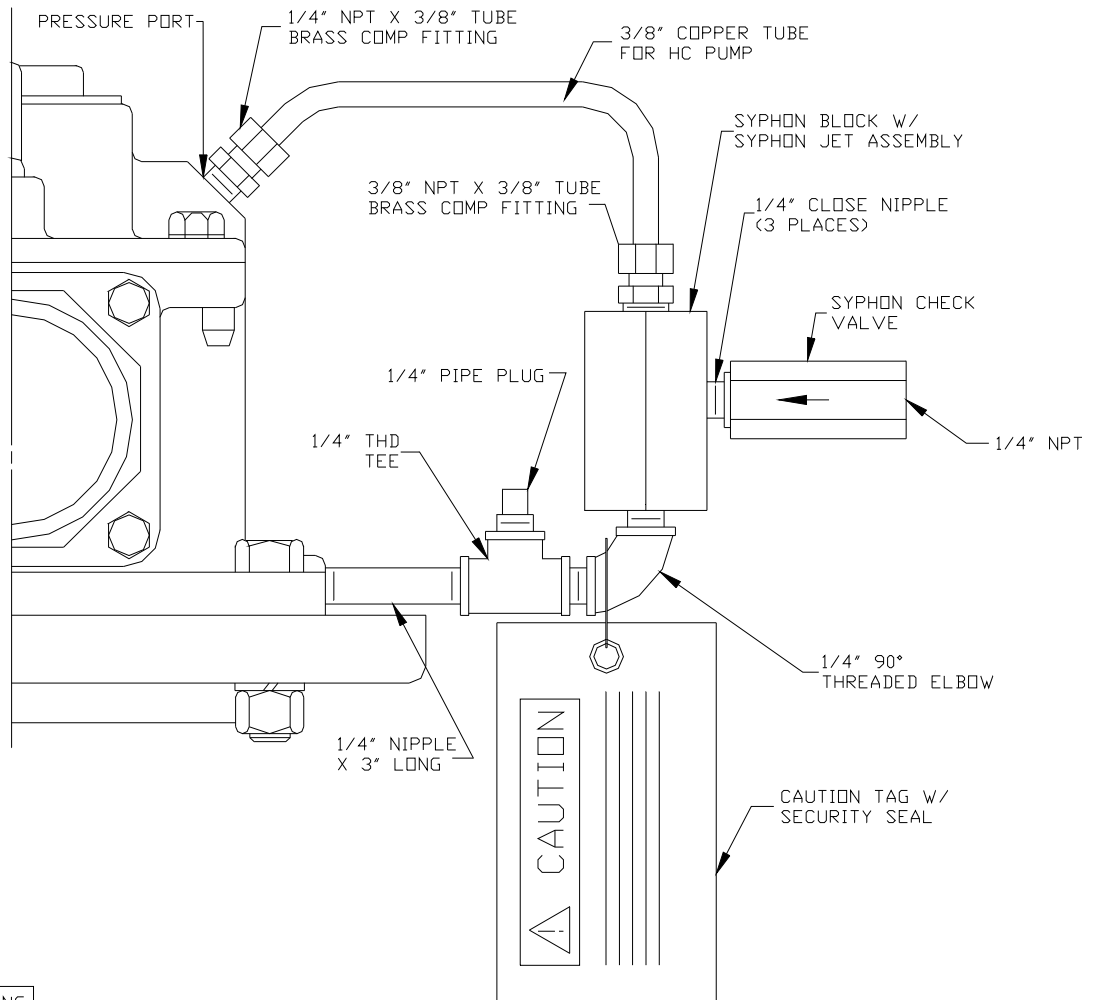

FIGURE 3



⚠ WARNING

REMOVE ALL POWER TO THE HIGH CAPACITY STP, FOLLOWING PROPER LOCK OUT & TAG OUT PROCEDURE, SEE HIGH CAPACITY STP INSTALLATION MANUAL FOR COMPLETE INSTRUCTIONS.

SYPHON UNIT INSTALLATION

1. REMOVE PIPE PLUGS FROM PRESSURE AND TANK PORTS.
2. ASSEMBLE SYPHON UNIT FITTINGS AND TUBE AS SHOWN.

⚠ CAUTION

FAILURE TO USE PROPER THREAD SEALING COMPOUND COULD RESULT IN A LACK OF SEALING WHERE THE FITTINGS THREAD INTO THE MANIFOLD, CREATING A POTENTIAL SITE FOR FUEL TO LEAK INTO THE ENVIRONMENT. A LEAK IN THIS ASSEMBLY WILL NOT BE DETECTED BY LINE LEAK DETECTION EQUIPMENT.

⚠ CAUTION

IN ASSEMBLY CARE MUST BE TAKEN TO PREVENT DIRT OR FOREIGN SUBSTANCE FROM GETTING INTO VALVE. ANY DIRT MAY CAUSE UNIT TO MALFUNCTION OR FAIL.

⚠ CAUTION

A LEAK IN THIS AUXILIARY SYPHON ASSEMBLY WILL NOT BE IDENTIFIED BY A LINE LEAK DETECTOR. A CONTAINMENT SUMP SENSOR AND VISUAL INSPECTION IS REQUIRED TO REDUCE RISK OF ENVIRONMENTAL CONTAMINATION FROM LEAKING FUEL.

FIGURE 4

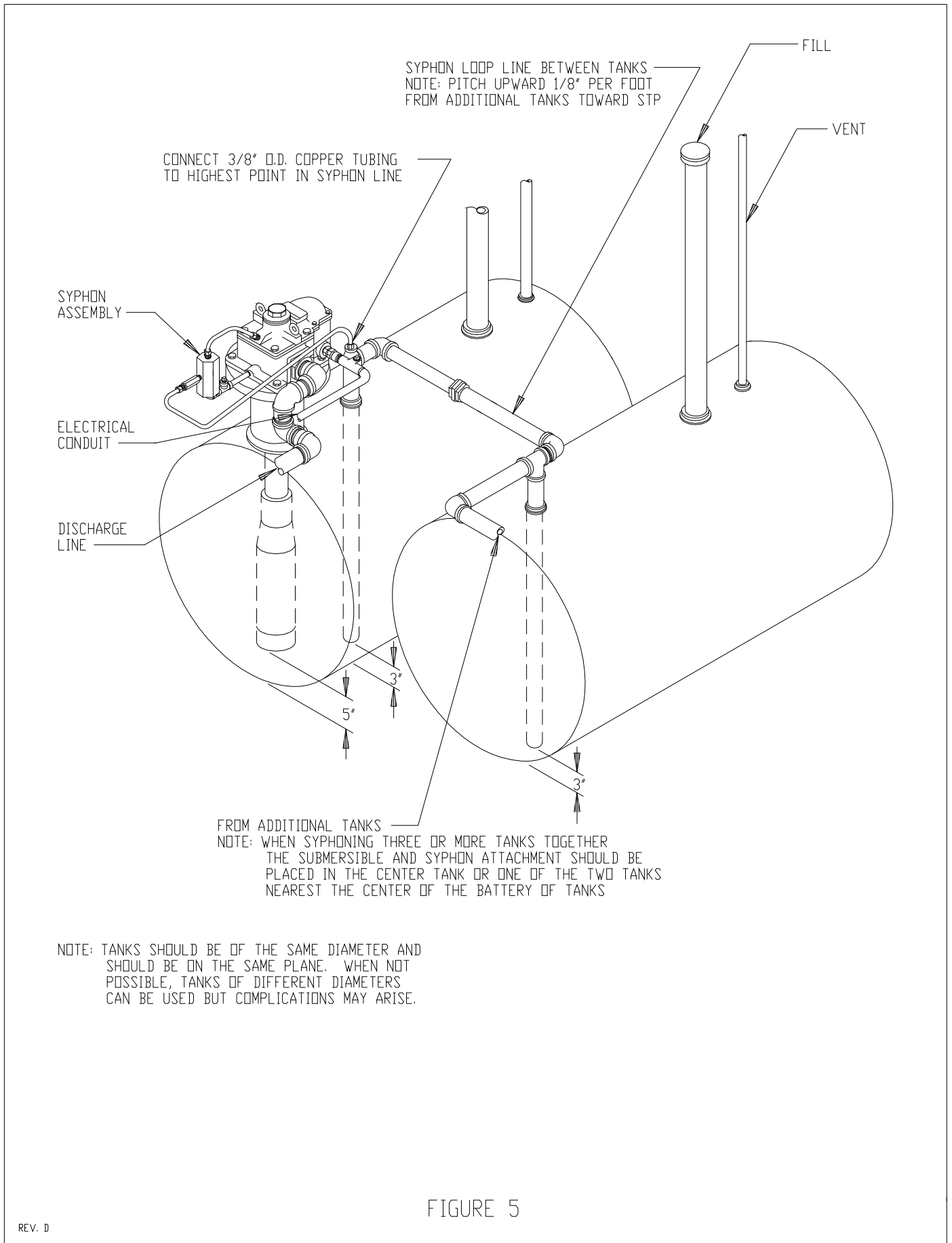

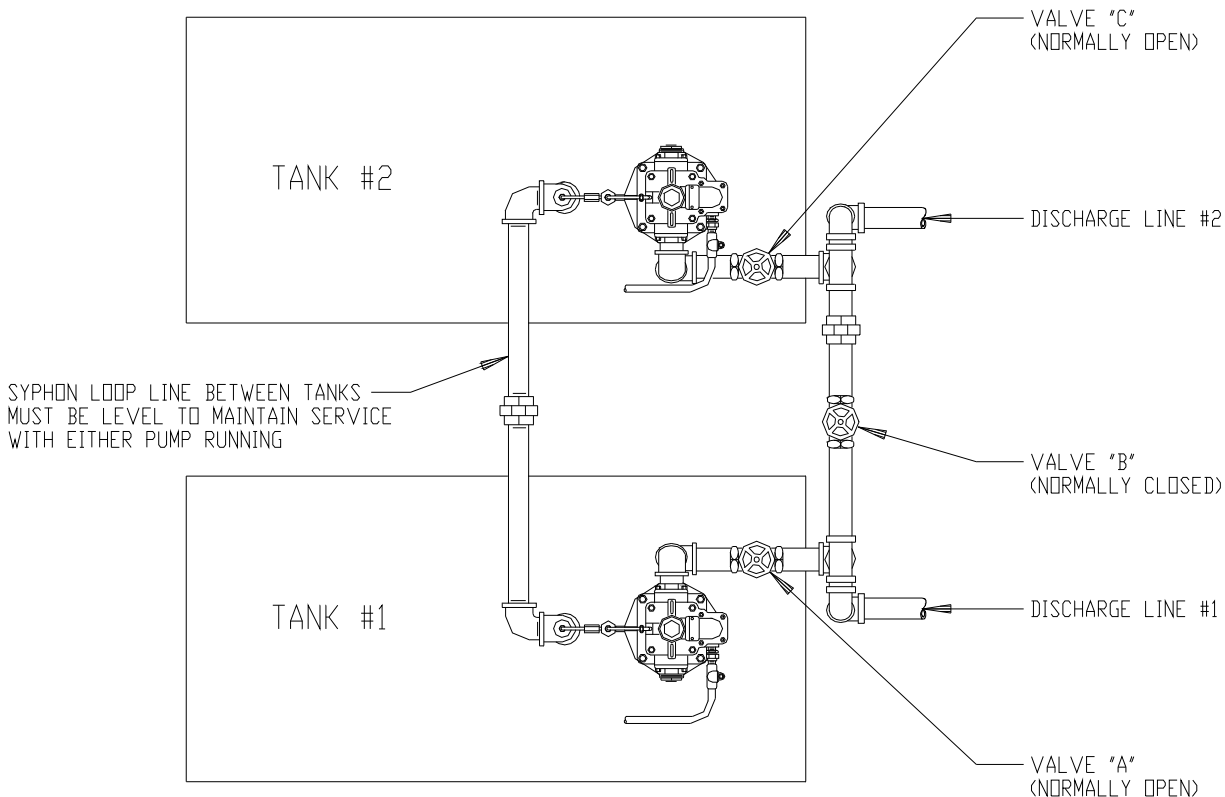

MANIFOLDED SYSTEM OPERATION

(FOR DISPENSING ONE PRODUCT WITH TWO SUBMERSIBLES)
 IN THIS TYPE OF INSTALLATION, A SUBMERGED PUMP IN EACH TANK #1 & #2 SUPPLIES TWO SEPARATE DISCHARGE LINES. BY THE USE OF VALVES AS SHOWN, ONE PUMP WILL SUPPLY BOTH DISCHARGE LINES TEMPORARILY. TO USE SUBMERSIBLE TANK #1 ONLY, CLOSE VALVE "C" AND OPEN VALVE "B" WITH VALVE "A" NORMALLY OPEN. TO USE SUBMERSIBLE TANK #2 ONLY, CLOSE VALVE "A" AND OPEN VALVE "B" WITH VALVE "C" NORMALLY OPEN.

NOTE: TANKS SHOULD BE OF THE SAME DIAMETER AND SHOULD BE ON THE SAME PLANE. WHEN NOT POSSIBLE, TANKS OF DIFFERENT DIAMETERS CAN BE USED BUT COMPLICATIONS MAY ARISE.

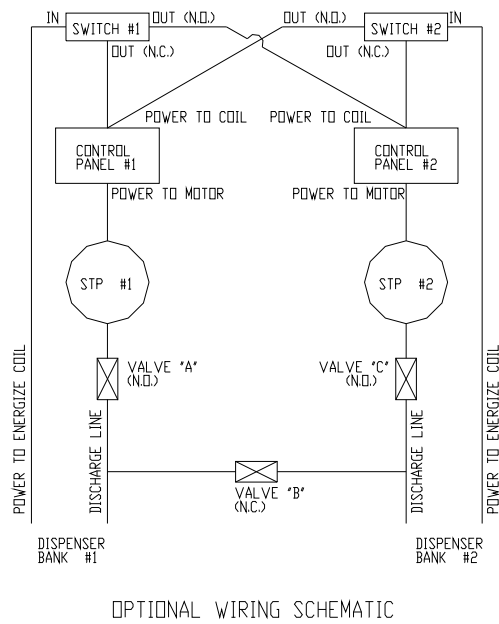

FIGURE 6

REV. C

HIGH CAPACITY GENERAL ASSEMBLY REPAIR PARTS

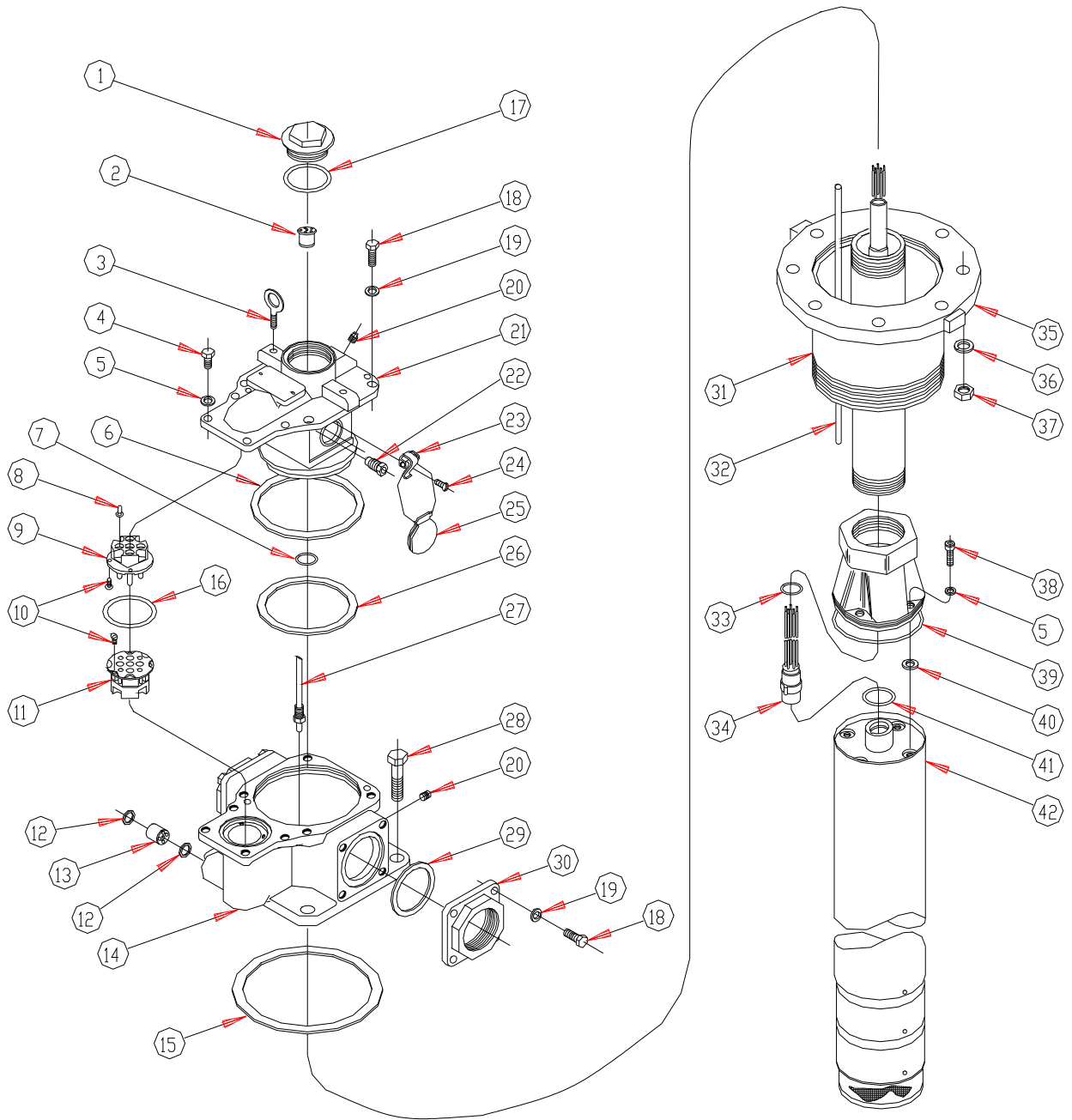

FIGURE 7

REV. C

High Capacity General Assembly Repair Parts

All Item Numbers Reference Figure 7

<u>Item No.</u>	<u>Part Number</u>	<u>Description</u>	<u>Quantity</u>
1	401148101	Connection Box Cover	1
2	400236909	Seal off Plug Assembly	1
3	401149001	Eye-Bolt	2
4	400258001	3/8-16 x 1 Lg Hx Hd Cap Screw	4
5	400285002	3/8 Lockwasher	8
6	401126002	Manifold Seal (Upper)	1
	401236002	Manifold Seal (Upper) (A/G compatible)	1
8	400273004	Wire Terminal (12 ga)	6
	400273006	Wire Terminal (14 ga)	4
9	401142901	Plug Assembly	1
10	401091001	6-32 x 3/8 Lg Rd Hd Mach Screw	6
11	401137901	Receptacle Assembly	1
12	401238001	Bushing Ring	2
13	401239001	Seal Plug	1
14	401112101	Discharge Manifold	1
15	401163001	Gasket	1
16	400211235	O-Ring	1
	400333235	O-Ring (A/G compatible)	1
17	400211234	O-Ring	1
	400333234	O-Ring (A/G compatible)	1
18	400258005	1/2-13 x 1-1/4 Lg Hx Hd Cap Screw	12
19	400285005	1/2 Lockwasher	12
20	400259001	1/4 Pipe Plug	2
22	401330901	Pressure Relief Valve	1
23	401154001	Valve Spring & Bracket	2
24	400523001	10-24 x 3/8 Lg Sems Fastener	4
25	401150901	Valve Assembly (Insep)	2
26	401126001	Manifold Seal (Lower)	1
	401236001	Manifold Seal (Lower) (A/G compatible)	1
27	401158901	Air Eliminator Assembly	1
28	400258006	3/4-10 x 3 Lg Hx Hd Cap Screw	4
29	401162001	Gasket	2
30	401113101	3" Companion Flange	2
31	4011910XX	6" Riser Pipe (6.625 OD x .25 WT) (XX indicates length)	1
32	400708002	Syphon Tube (5/16 OD x .035 WT) (specify length)	1
33	400211218	O-Ring	1
	400333218	O-Ring (A/G compatible)	1
34	151593906	Lead Connector Assembly	1
35	401161101	6" Flange	1
36	400285006	3/4 Lockwasher	4
37	400274004	3/4-10 Hex Nut	4
38	400264011	3/8-16 x 1-1/4 Lg SHCS	4
39	400210255	O-Ring	1
	400333255	O-Ring (A/G compatible)	1
40	402406001	Rubber Washer	4
41	400333225	O-Ring (A/G compatible)	1
42	PMA XXX	Pump Motor Assembly (XXX indicates horsepower & model)	1
(not shown)	400579901	Precision Relief Valve Assembly (Replaces item 22) (Includes items 38, 5, 39, 40, 41)	1

HIGH CAPACITY SYPHON SYSTEM REPAIR PARTS

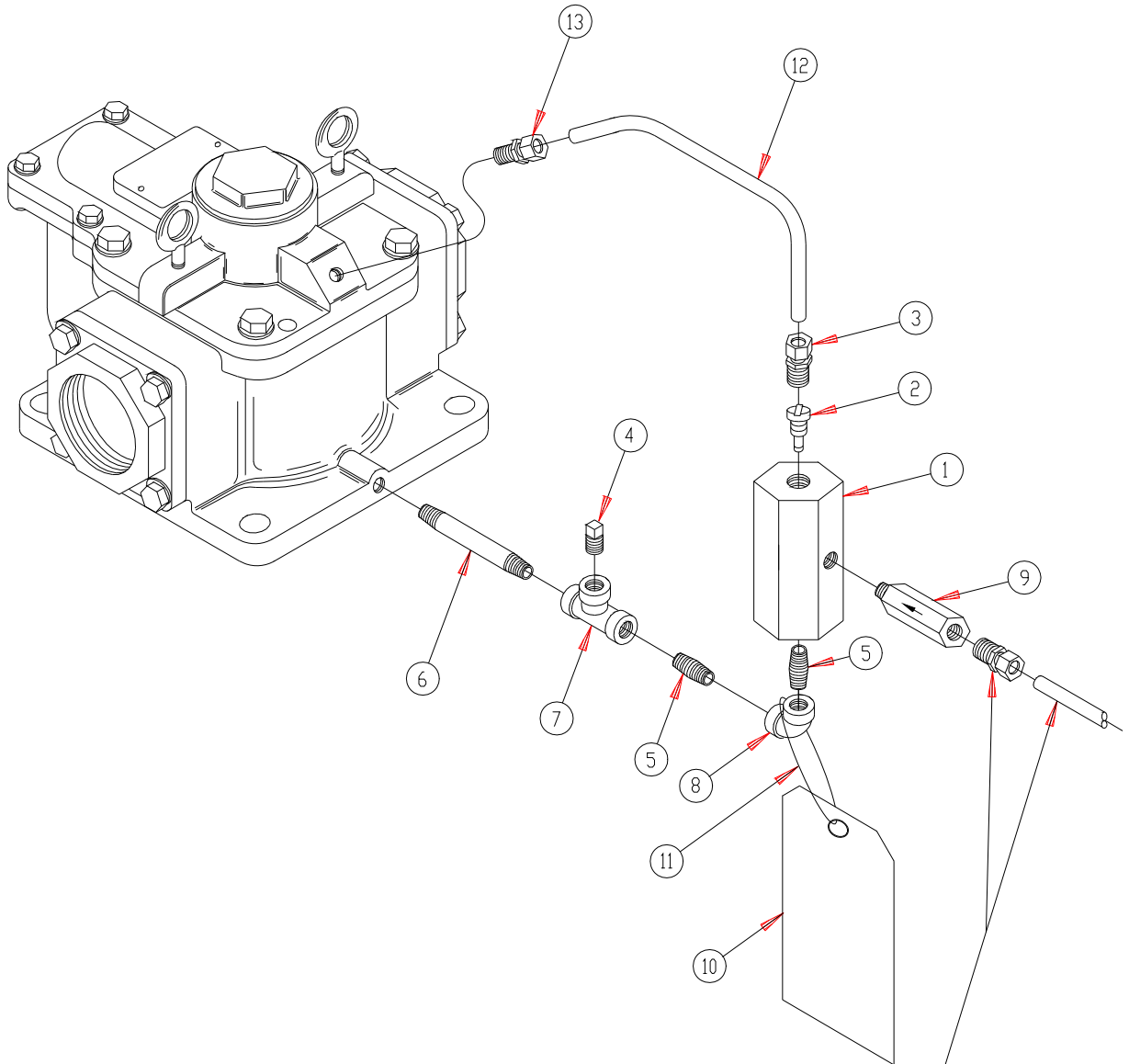

NOTE: CONNECT 1/4" MPT X 3/8" TUBE FITTING
TO CHECK VALVE & 3/8" O.D. COPPER
TUBING TO HIGHEST POINT IN SYPHON LINE
(FURNISHED BY CUSTOMER)

FIGURE 8

High Capacity Syphon System Repair Parts

All Item Numbers reference Figure 8

<u>Item No.</u>	<u>Part Number</u>	<u>Description</u>	<u>Quantity</u>
1	402505001	Syphon Block	1
2	400562901	Syphon Jet Assy	1
3	400430004	3/8P x 3/8T Compression Fitting	1
4	400259001	¼ Pipe Plug	1
5	400114001	¼ Close Nipple	2
6	400114003	¼ Nipple x 3 long	1
7	402510001	¼ Threaded Tee	1
8	402511001	¼ Threaded Elbow 90	1
9	400137907	Syphon Check Valve	1
10	402544001	Caution Tag	1
11	400982001	Security Seal	1
12	402553902	Copper Tube (HC Pump)	1
13	400430003	1/4P x 3/8T Compression Fitting	1

Final Assembly (Includes all syphon items)

401165930 Syphon Unit Complete

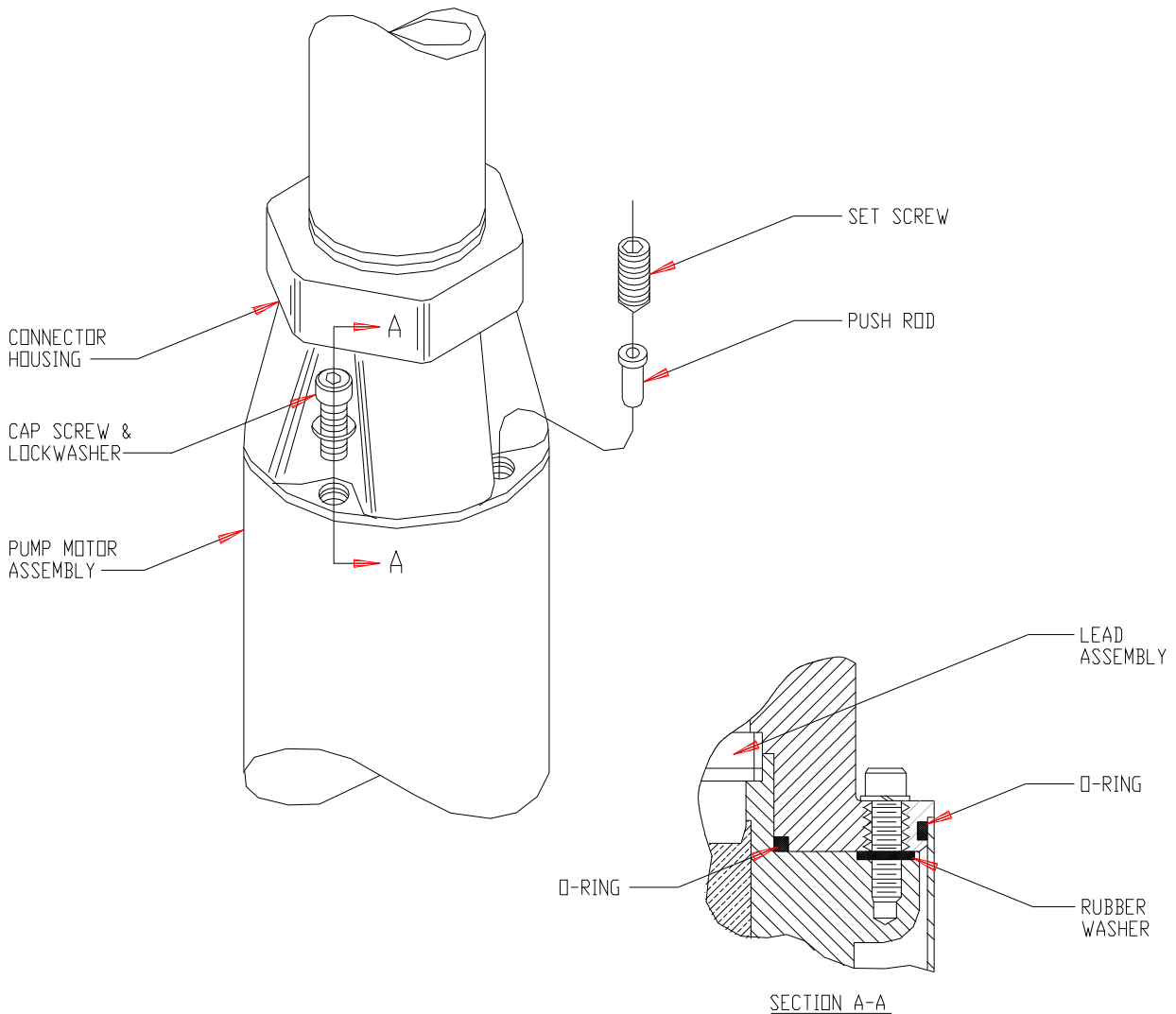

PUMP MOTOR REPLACEMENT

1. REMOVE (4) SOCKET HEAD CAP SCREWS & (4) LOCKWASHERS.
2. PLACE (2) PUSH RODS & (2) 1/2-13 x 1" LONG HEADLESS SET SCREWS (FURNISHED WITH REPLACEMENT PMA) IN HOLES OPPOSITE EACH OTHER.
3. TURN SET SCREWS CLOCKWISE UNTIL PRESSURE IS FELT, THEN ALTERNATELY TURN EACH SCREW UNTIL PUMP MOTOR ASSEMBLY IS FREE OF CONNECTOR HOUSING.
4. INSTALL NEW (2) O-RINGS & (4) RUBBER WASHERS AS SHOWN IN SECTION A-A. ATTACH NEW PUMP MOTOR ASSEMBLY WITH (4) SOCKET HEAD CAP SCREWS & LOCKWASHERS, DRAW PUMP MOTOR ASSEMBLY TIGHT TO CONNECTOR HOUSING WITH SCREWS.

CAUTION: KEY ON LEAD ASSEMBLY PLUG CONNECTOR MUST LINE UP INTO KEYWAY OF CONNECTOR HOUSING FOR PROPER MATING WITH PUMP MOTOR ASSEMBLY RECEPTACLE.

FIGURE 9

REV. A

This page intentionally left blank



FE PETRO[®]
Franklin Fueling Systems

3760 Marsh Road • Madison, WI 53718 U.S.A.

Tel: +1 608 838 8786 • Fax: +1 608 838 6433 • www.franklinfueling.com

Tel: USA & Canada 1 800 225 9787 • Tel: Mexico 001 800 738 7610