

STP Ordering Guide

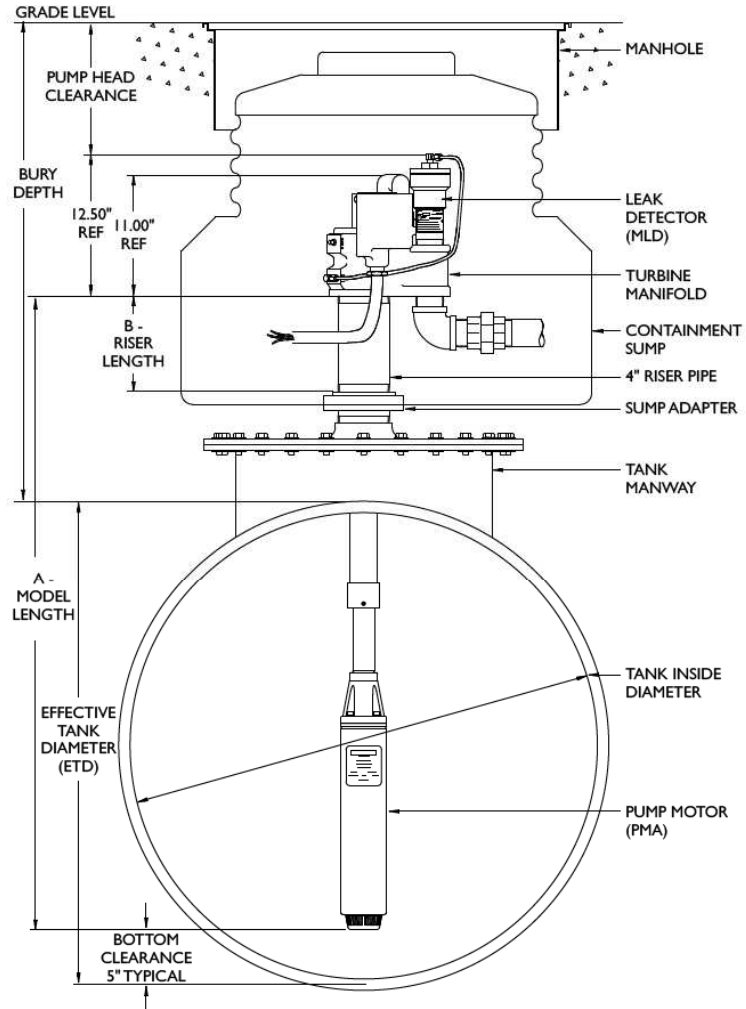

- Notes: 1. Effective tank diameter (ETD) = Inside tank diameter (to top of 4" bung), including tank manway and/or sump adapter.
 2. Model length (A) = ETD plus riser length minus bottom clearance minus 1" thread engagement.
 3. Riser length (B) = Bury depth (to top of tank) minus pump head clearance minus tank manway and/or minus sump adapter.