

FILL-RITE®

SERIES BD310

115 and 230 VOLT AC

FUEL TRANSFER PUMP FOR BIODIESEL B21-B100

(Biodiesel must conform to ASTM D6751 Standard)

Owner's Operation and Safety Manual



Model BD310



CAUTION

Not for use with gasoline, diesel fuel or biodiesel less than B21. Use the Fill-Rite® Series FR300 pump to dispense gasoline & the Series FR310 pump to dispense diesel fuel.



SAFETY INSTRUCTIONS

To ensure safe and efficient operation, it is essential to read and follow each of these warnings and precautions.

1. Improper use or installation of this product can cause serious bodily injury or death.
2. Do NOT smoke near pump or use pump near an open flame. Fire could result.
3. Disconnect power to pump before servicing pump.
4. Take motors needing service to an authorized repair shop to maintain "explosion-proof" and "rain-proof" integrity.
5. A biodiesel compatible filter should be used on pump outlet to ensure that no foreign material is transferred to fuel tank.
6. The pump motor is equipped with thermal overload protection. If overheated, it will shut itself off without any damage to the windings. Turn off the pump power if this occurs. When the motor cools, it will restart without warning if power is on.
7. Storage tank should be anchored to prevent tipping in both the full and empty conditions.
8. To minimize static electricity build-up, keep nozzle in contact with container being filled while filling container.



DANGER



Electrical wiring should be done by a licensed electrician in compliance with local, state and national electrical code, ANSI/NFPA 70, 30, 30A as appropriate. Rigid conduit should be used and a proper ground must be provided to avoid the possibility of electrical shock. Failure to comply with this warning could result in serious injury and/or loss of property. Use only static wire, conductive hose when pumping flammable fluids.



WARNING

Do not use this product for fluid transfer into aircraft. This product is not suited for use with fluids for human consumption or fluids containing water.

GENERAL DESCRIPTION

The Fill-Rite Series BD310 products are positive displacement, rotary vane pumps. Their rugged motors are explosion-proof and rain-proof to ensure a long life of dependability.

MECHANICAL INSTALLATION INSTRUCTIONS

Pump has a built-in check valve with pressure relief to prevent fluid thermal expansion from causing unsafe system pressures.

Do NOT use additional check valves or foot valves unless they have a proper pressure relief valve built into them.

Pumps are furnished with a tank adapter for tank mounting; pedestals are available for island installations. All tanks must be properly vented. Biodiesel compatible filters are recommended when dispensing into vehicles.

Use oil resistant pipe sealant on all pipe threads to protect against leaks.

SKID TANK MOUNTING (See figure 1)

1. Cut a 1-1/2" pipe that will extend to 3" above bottom of tank when screwed into tank adapter and tank adapter is screwed into tank.
2. Screw pipe into tank adapter, then screw tank adapter into tank.
3. Mount pump on tank adapter.

Figure 1. SKID TANK INSTALLATION

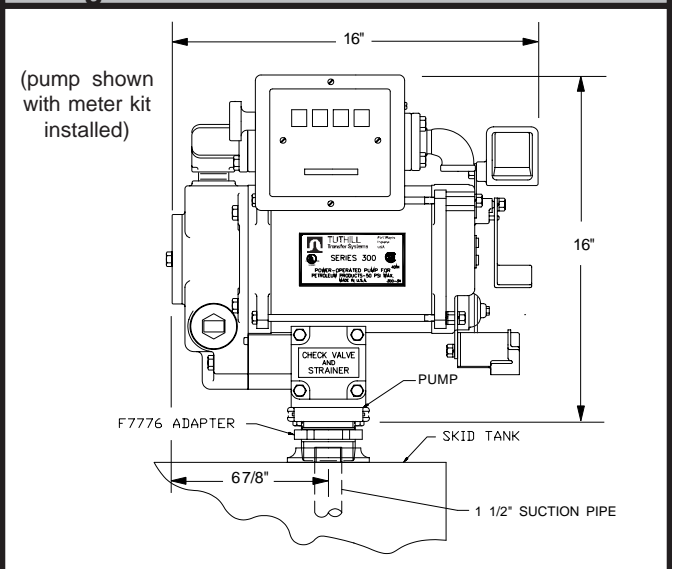

DIRECT MOUNTING TO UNDERGROUND TANK (see figure 2)

1. Cut and thread both ends of a 2" pipe that will extend about 31" above the ground when installed in tank.
2. Install this pipe in tank. Screw 2" standard pipe coupling onto top of pipe.
3. Cut a 1-1/2" pipe that will extend to 3" above bottom of tank when screwed into tank adapter and tank adapter is screwed into 2" coupling.
4. Screw this pipe into tank adapter, then screw tank adapter into 2" coupling.
5. Mount pump on tank adapter.

Figure 2. DIRECT MOUNTING INSTALLATION

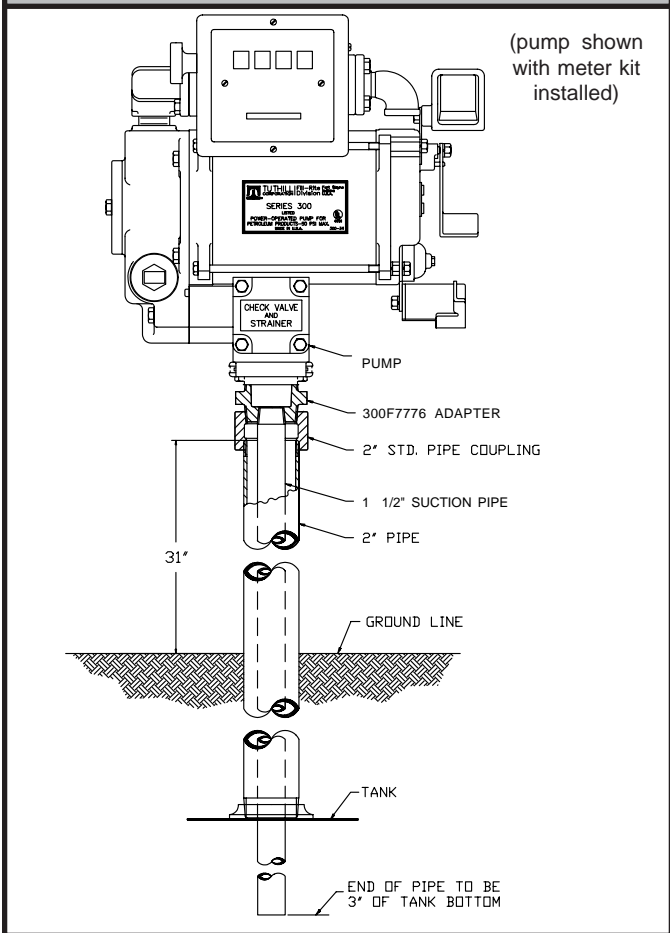
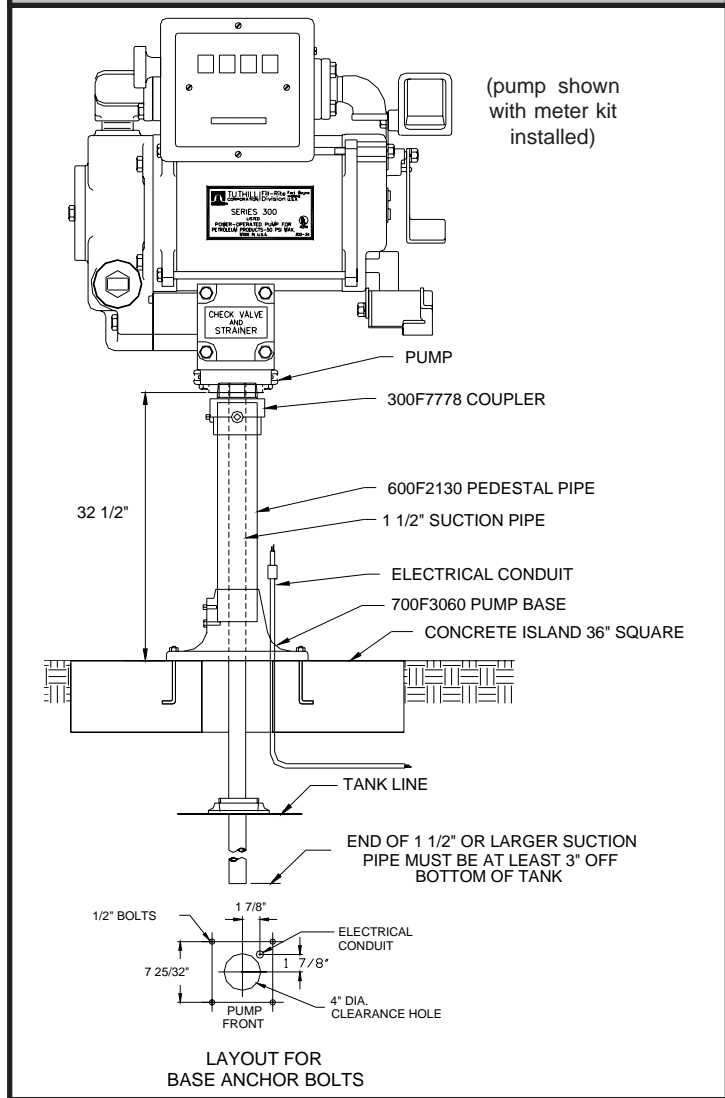

Figure 3. TYPICAL ISLAND INSTALLATION



ISLAND INSTALLATION (see figure 3)

1. Install tank and piping per illustration.
2. The threaded 1-1/2" suction pipe is to extend 32-1/2" above island.
3. Remove coupler from pedestal pipe by loosening set screws.
4. Slip pedestal pipe base assembly over suction pipe.
5. Loosen screws in pedestal base to allow pedestal pipe to slide down exposing end of suction pipe.
6. Screw coupler onto suction pipe.
7. Slide pedestal pipe into coupler, tighten set screws. Tighten screws in pedestal base.
8. Mount pump on coupler.

ELECTRICAL INSTALLATION INSTRUCTIONS

1. Install pump as described in Mechanical Installation Instructions. **Read and understand all the electrical wiring instructions before proceeding.**

Pump motor voltage is factory set at 115 VAC. See figure 4 to change voltage setting.

2. Remove pump's electrical junction box cover and straighten the wires to make the stripped wire ends accessible outside of the junction box.

WARNING: AUX. WIRE IS LIVE WIRE (see figure 4). The AUX. lead wire (orange) is insulated and enclosed when shipped. **Do not connect this wire without first verifying the 'ON' line voltage of the wire for compatibility to the equipment to be installed. Maximum amperage on wire is 1 ampere. The wire must be insulated and enclosed in the junction box if not used.**

3. Power to the unit should be supplied from a dedicated 30 amp circuit breaker. No other equipment should be powered from this breaker. Threaded rigid conduit, seal fittings and conductor seal

Figure 4. WIRE DIAGRAM, Series BD310

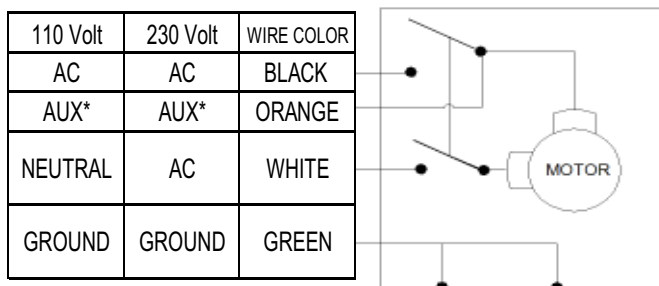

***WARNING: AUX. WIRE IS LIVE WIRE!**

The AUX. lead wire is insulated and enclosed when shipped. **Do not connect this wire without first verifying the 'ON' line voltage of the wire for compatibility to the equipment to be installed. Maximum amperage on wire is 1 ampere. The wire must be insulated and enclosed in the junction box if not used.**

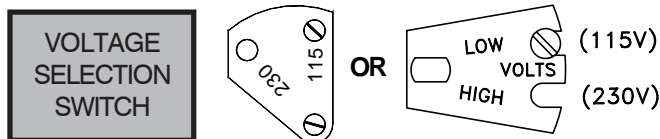

Voltage select screw should be placed next to correct voltage setting (115 VAC shown)

300 SERIES PUMP PARTS LIST

ITM. NO.	PART NO.	DESCRIPTION	QTY.
1	300G7376	Motor - 3/4 HP 115/230 VAC, 50/60 Hz (Models FR310, FR311)	1
3	300F7787	Rotor Insert	1
4	300KTH0034	Seal Assembly Kit (Includes Items 11&15)	1
5	300G9285	O-Ring Gasket Fluorocarbon (-236)	1
6	700G7063	Rotor Cover	1
7	300G7296	3/8-16 x 3/4 HHCS	2
8	300G8379	Rotor	1
9	300H0532	Vanes	8
10	300F7746	3/8-16 x 3 HHCS	2
11	700F2688	Retaining Ring (Included w/Item 4)	1
12	300F7723	Bypass Valve Assembly	1
13	800F4381	O-Ring Fluorocarbon 2-131	1
14	300F7731	Bypass Cap	1
15	30F4660	Seal Washer (Included w/Item 4)	1
16	700F2810	5/16-18 x 7/8 HHCS	4
17	300F7739	Check Valve Cover	1
18	400F0191	O-Ring Gasket Fluorocarbon (-231)	1
19	300F7735	Check Valve Assembly	1

ITM. NO.	PART NO.	DESCRIPTION	QTY.
20	300G8621	Lower Housing	1
22	3007788	Inlet gasket (fluorocarbon -224)	1
23	300F8688	Pump Housing (Models FR310 & FR311)	1
25	300F7776	2" x 1 1/2" Tank Adapter	1
27	300G9432	Washer 1/4" Split lock	1
28	300G9273	10-32NC-2B X 1.50 SHCS	1
31	700F2810	5/16-18 x .875 HHCS	4
32	300G9129	O-ring 2-146	1
33	304F7904	1/4-20 1/2 HWHMS	4
34	300F7761	Switch Lever	1
35	300G8967	Junction Box	1
36	300G8971	Junction Box Cover	1
38	300F7773	1" x 12' Hose	1
39	800F4400	1" Street Elbow	1
40	300F7745	3/8-16 x 2 HHCS	2
41	300F7765	Nozzle Cover	1
42	BDH0709	1" Manual Nozzle Biodiesel	1
43	300F7759	Locking Link	1
44	700F2950	5/16 Lock Nut	2
	BDH0708	1" Automatic Hi-flow Nozzle	opt

BD300KTH0712	Repair Kit (Includes items 3-6, 8, 9, 12, 13, 18 & 22)
300KTH0034	Seal Kit (Includes item 6)

ACCESSORIES

TH14	Pedestal Kit
BD901MK	Meter Kit

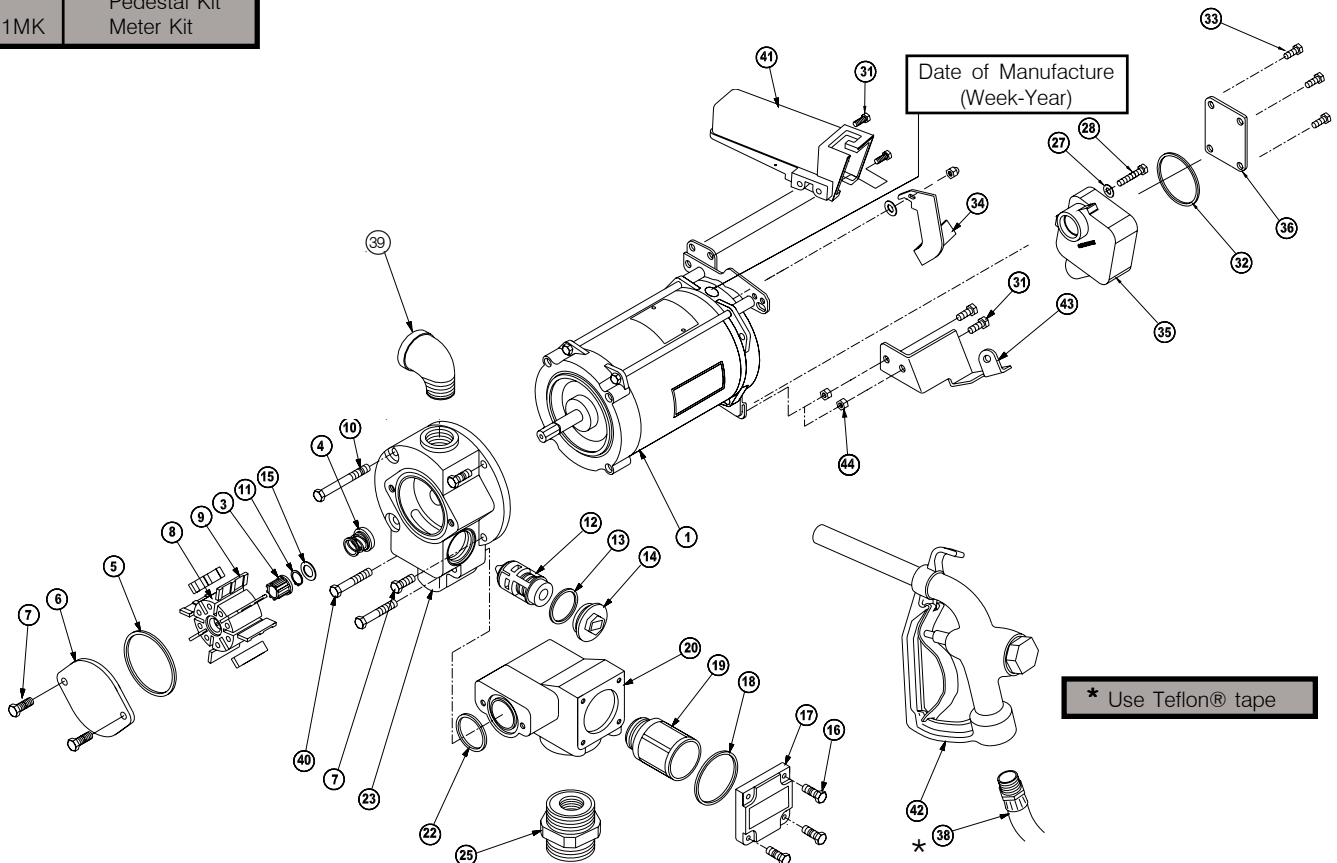

8825 Aviation Drive
Fort Wayne, Indiana USA 46809
Tel 260 747-7524 Fax 260 747-3159

Electrical Installation Instructions (continued)

- should be used. Provisions must be made to break both legs of any AC circuit. Connect like colored pump wires to supply wires. Ground wire must be connected.
4. Fold wires into junction box and replace cover making sure that gasket is in place. Make sure screws are seated so there is no space between the cover and the junction box.

OPERATING INSTRUCTIONS

1. Reset meter to 0 (if applicable).
2. Remove nozzle from nozzle boot and move switch lever up. This will turn the pump on.
3. Insert nozzle into container to be filled. To minimize static electricity buildup, keep nozzle in contact with container while dispensing fluid.
4. Operate nozzle lever to dispense fluid.
5. When desired amount of fluid has been dispensed, release nozzle lever, remove nozzle from container, move switch lever to down position to turn off pump, and replace nozzle in boot.

TROUBLESHOOTING

IF PUMP FAILS TO PRIME:

- Check suction line for leaks or obstructions.
- Check bypass valve for dirt. The bypass poppet should slide freely.
- Open nozzle to allow air to escape from system

PUMP WILL NOT START:

- If motor hums but will not start, a probable cause is a stuck rotor. Remove rotor cover; check rotor and vanes for dirt.
- Have an electrician check the electrical power to the pump.

LOW PUMPING CAPACITY:

- Strainer screen clogged
- Bypass valve not seated properly
- Obstruction in suction lines.
- Make sure all 8 vanes slide easily in the rotor slots.

BIODIESEL NOTES

Definition: Biodiesel is a clean burning fuel made from vegetable oil or animal fat that has been processed to meet the requirements of ASTM D6751 standard. Only biodiesel that meets the ASTM D6751 standard are to be used with Fill-Rite Series BD310 pumps. Unprocessed or recycled vegetable oil are not biodiesel and are not to be used with the Fill-Rite Series BD310 pumps.

Biodiesel is often blended with petroleum diesel fuel. When blended, the resulting fuel is known by the percentage of biodiesel in the blend; ie. a 20% biodiesel blend with 80% petroleum diesel is known as B20. Pure biodiesel is B100, also known as "Neat" biodiesel. Blends with 20% biodiesel or less (B1-B20) are generally treated like petroleum diesel fuel.

The Fill-Rite Series BD310 Transfer Pumps are designed to handle biodiesel blends of B21–B100 (21%-100% biodiesel). Users who wish to dispense blends with lower concentrations of biodiesel (B1-B20) should use the Fill-Rite Series **FR**310 fuel pumps.

Temperature Limitations: B100 (100% biodiesel) that meets ASTM D6751 has a "gel" point of 38°F (3.3°C). If B100 gets colder than 40°F (4.4°C), the Fill-Rite Series BD310 Transfer Pumps may not operate properly due to the thickness of the fluid. In some situations, tank manufacturers may be able to supply tank and pipeline heaters that are safe to use and can keep the temperature of the B100 above 40°F.

Cleaning Properties of Biodiesel: Biodiesel has scrubbing and cleaning properties that tend to loosen rust, varnish, and dirt in storage tanks, piping, and equipment. The resulting debris can clog filters and screens, or damage equipment. It is important to understand this and take precautions to prevent problems when first using biodiesel.

Shelf Life of Biodiesel: It is recommended that biodiesel be used within 6 months for best performance. Microbial growth may occur if biodiesel is stored for longer periods.

For more information on biodiesel, go to www.biodiesel.org.

PRODUCT WARRANTY

Tuthill Transfer Systems ("Manufacturer") warrants to each consumer buyer of its Fill-Rite products (the "Buyer"), from the date of invoice or sales receipt, that goods of its manufacture ("Goods") will be free from defects of material and workmanship. Duration of this warranty is as follows:

- Heavy Duty Products - Two years
- Standard Duty Products – One year
- Economy Duty Products – One year
- Cabinet pumps, Parts, and Accessories - One year

Manufacturer's sole obligation under the foregoing warranties will be limited to either, at Manufacturer's option, replacing or repairing defective Goods (subject to limitations hereinafter provided) or refunding the purchase price for such Goods theretofore paid by the Buyer, and Buyer's exclusive remedy for breach of any such warranties will be enforcement of such obligations of Manufacturer. If Manufacturer so requests the return of the Goods, the Goods will be redelivered to Manufacturer in accordance with Manufacturer's instructions F.O.B. Factory. The remedies contained herein shall

constitute the sole recourse of the Buyer against Manufacturer for breach of warranty. IN NO EVENT SHALL MANUFACTURER'S LIABILITY ON ANY CLAIM FOR DAMAGES ARISING OUT OF THE MANUFACTURE, SALE, DELIVERY, OR USE OF THE GOODS EXCEED THE PURCHASE PRICE OF THE GOODS. The foregoing warranties will not extend to Goods subjected to misuse, neglect, accident or improper installation or maintenance, or which have been altered or repaired by anyone other than Manufacturer or its authorized representative. THE FOREGOING WARRANTIES ARE EXCLUSIVE AND IN LIEU OF ALL OTHER WARRANTIES OF MERCHANTABILITY, FITNESS FOR PURPOSE OF ANY OTHER TYPE, WHETHER EXPRESS OR IMPLIED. No person may vary the foregoing warranties and remedies except in writing signed by a duly authorized officer of Manufacturer. Warranties or remedies that differ from the foregoing shall not otherwise be binding on Manufacturer. The Buyer's acceptance of delivery of the Goods constitutes acceptance of the foregoing warranties and remedies, and all conditions and limitations thereof.



www.tuthill.com

8825 Aviation Drive
Fort Wayne, Indiana USA 46809
Tel 260 747-7524 Fax 260 747-3159