

ABCE

Basic Pedestal

Self Priming Centrifugal Pump

Models 81 1/2B3-B and 81 1/2B52-B

Size 1 1/2" x 1 1/2"



PUMP SPECIFICATIONS

Size: 1 1/2" x 1 1/2" NPT (38,1 mm x 38,1 mm) NPT - Female.

Casing: Gray Iron No. 30.

Maximum Operating Pressure 55 psi (379 kPa)*.

Semi-Open Type, Three Vane Impeller: Gray Iron No. 30.

Handles 5/8" (15,8 mm) Diameter Spherical Solids.

Impeller Shaft: Carbon Steel No. 1215.

Replaceable Wear Plate: Carbon Steel No. 1026.

Pedestal: Gray Iron No. 30.

Seal Plate: Gray Iron No. 30.

Flap Valve: Buna-N w/Nylon Reinforcement,
Gray Iron No. 30 and Steel.

Shaft Sleeve: Stainless Steel No. 304.

Radial and Thrust Bearings: Open Single Row Ball.

Bearing Lubrication: Grease.

Flange: Gray Iron No. 30.

Gaskets: Cork.

Hardware: Standard Plated Steel.

Discharge Service Tee: Ductile Iron.

Optional Equipment:

All Iron Construction. Strainer.

Consult Factory for Additional Options.

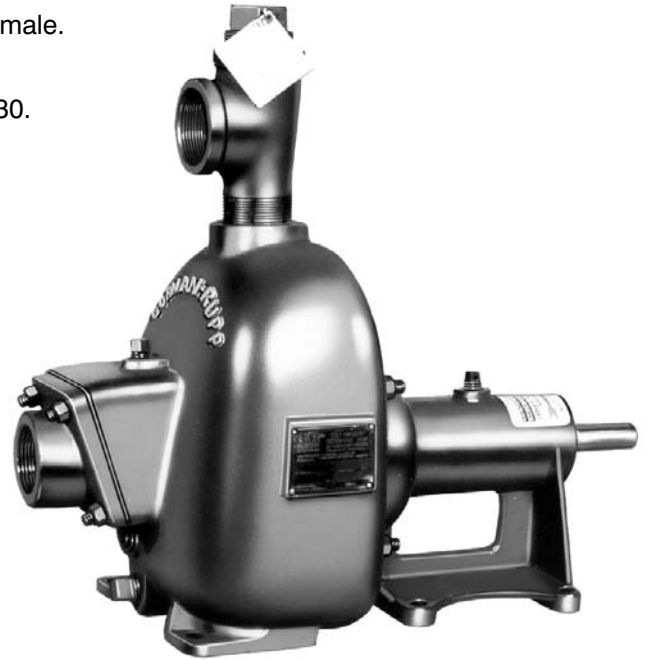

**Consult Factory for Applications Exceeding Maximum Pressure and/or Temperature Indicated.*

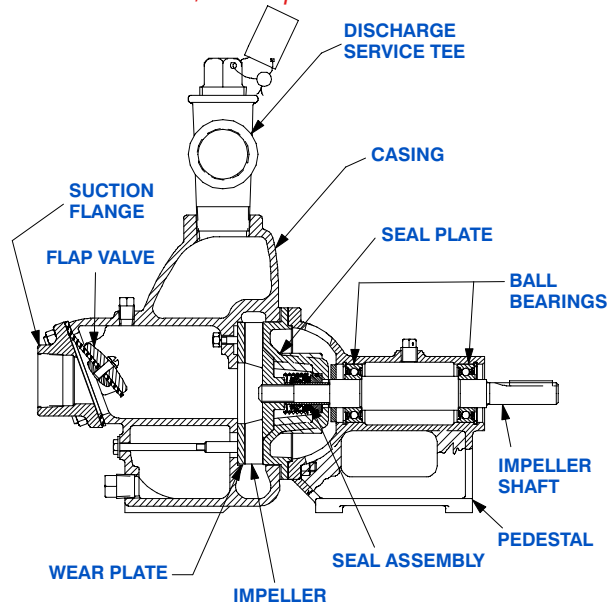

81 1/2B3-B SHOWN

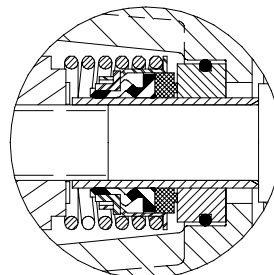

81 1/2B3-B SEAL DETAIL: Type 2, Mechanical, Self Lubricated. Carbon Rotating Face and Ceramic Stationary Face. Buna-N Elastomers. 18-8 Stainless Steel Cage and Spring. Maximum Temperature of Liquid Pumped, 160°F (71°C)*.

81 1/2B52-B SEAL DETAIL: Type 31, Mechanical, Self-Lubricated. Silicon Carbide Rotating and Stationary Faces. Fluorocarbon Elastomers (DuPont Viton® or Equivalent). Stainless Steel No. 316 Cage and Spring. Maximum Temperature of Liquid Pumped 160°F (71°C)*.

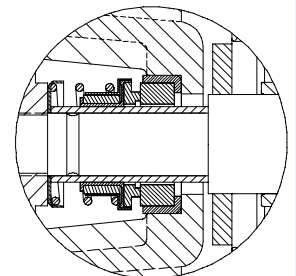

COURTESY OF
MASCOTT EQUIPMENT COMPANY
Portland Seattle Tri-Cities
www.mascottec.com

Printed in U.S.A.

Specification Data

SECTION 50, PAGE 976

APPROXIMATE
DIMENSIONS and WEIGHTS

NET WEIGHT: 58 LBS. (26,3 KG.)
SHIPPING WEIGHT: 68 LBS. (30,8 KG.)
EXPORT CRATE: 3.5 CU. FT. (0,10 CU. M.)

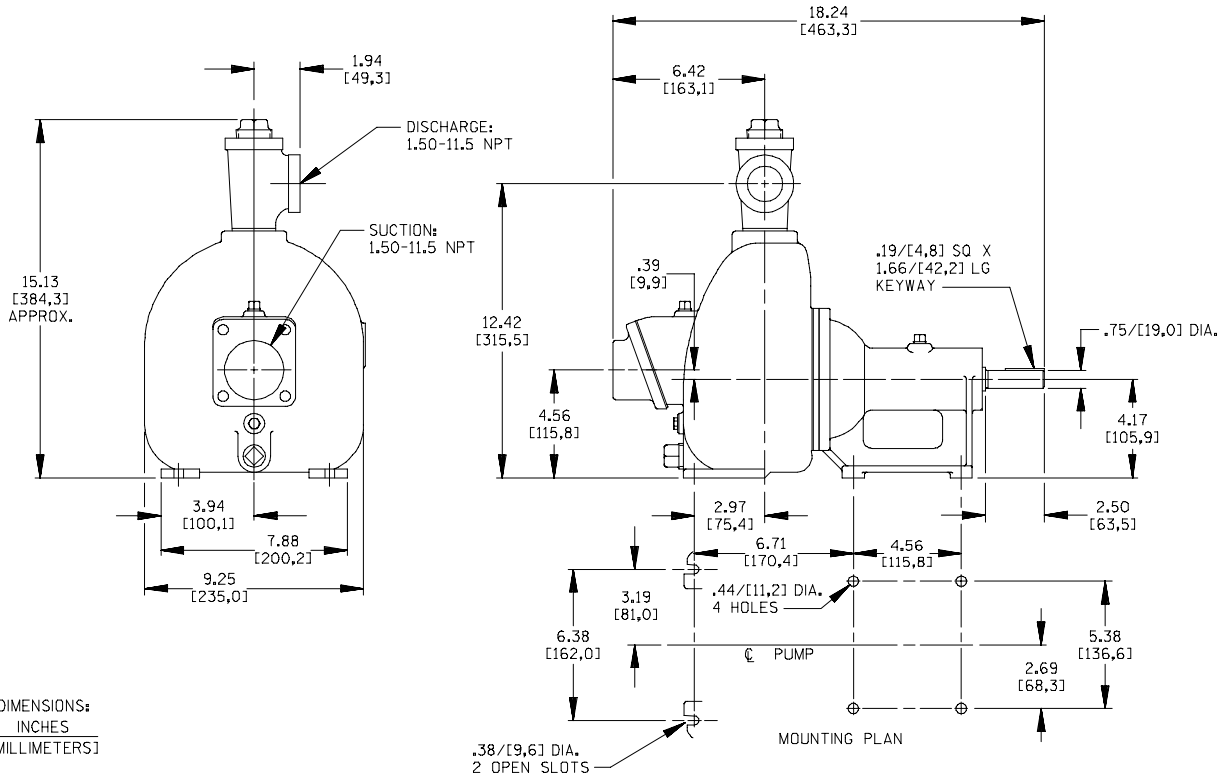

DIMENSIONS:
INCHES
[MILLIMETERS]

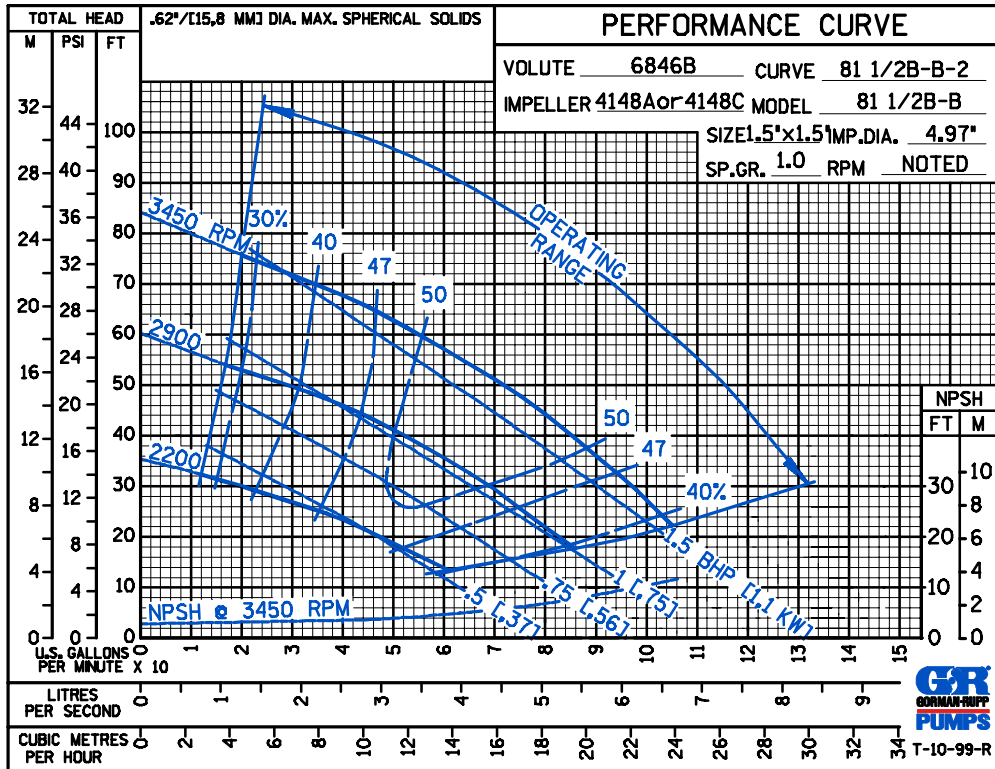

THE GORMAN-RUPP COMPANY • MANSFIELD, OHIO

GORMAN-RUPP OF CANADA LIMITED • ST. THOMAS, ONTARIO, CANADA

Specifications Subject to Change Without Notice

Printed in U.S.A.