

A B C D E

Basic Pedestal

Self Priming Centrifugal Pump

Models 82D3-B and 82D52-B

Size 2" x 2"



PUMP SPECIFICATIONS

- Size:** 2" x 2" (51 mm x 51 mm) NPT - Female.
- Casing:** Gray Iron No. 30.
Maximum Operating Pressure 69 psi (476 kPa)*.
- Semi-Open Type, Three Vane Impeller:** Gray Iron No. 30.
Handles 5/8" (15,9 mm) Diameter Spherical Solids.
- Impeller Shaft:** Carbon Steel No. 1215
- Replaceable Wear Plate:** Carbon Steel No. 1026.
- Pedestal:** Gray Iron No. 30.
- Shaft Sleeve:** Stainless Steel No. 304.
- Seal Plate:** Gray Iron No. 30.
- Flap Valve:** Buna-N^W/Nylon Reinforcement, Gray Iron No. 30 and Steel.
- Radial and Thrust Bearings:** Open Single Row Ball.
- Bearing Lubrication:** Grease.
- Flange:** Gray Iron No. 30.
- Gaskets:** Cork.
- Hardware:** Standard Plated Steel.
- Optional Equipment:**
Galvanized Ductile Iron Discharge Elbow.
Consult Factory for Additional Options.



**Consult Factory for Applications Exceeding Maximum Pressure and/or Temperature Indicated.*

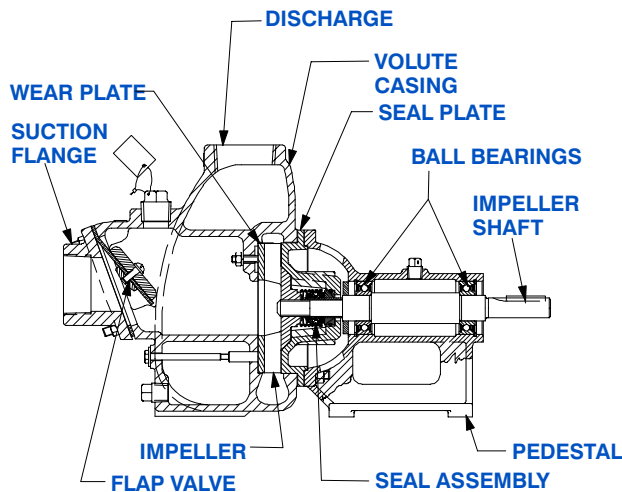

82D3-B SHOWN

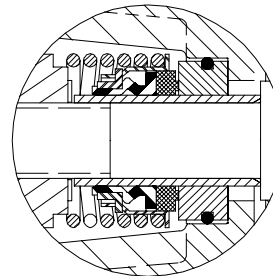

82D3-B SEAL DETAIL Type 2, Mechanical, Self-Lubricated. Carbon Rotating Face. Ceramic Stationary Face. Buna-N Elastomers. Stainless Steel No. 18-8 Cage and Spring. Maximum Temperature of Liquid Pumped, 160°F (71 °C).*

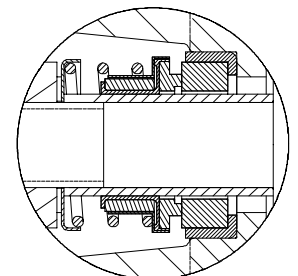

82D52-B SEAL DETAIL Type 31, Mechanical, Self-Lubricated. Silicon Carbide Rotating and Stationary Faces. Fluorocarbon Elastomers (DuPont Viton[®] or Equivalent). Stainless Steel No. 316 Cage and Spring. Maximum Temperature of Liquid Pumped 160°F (71 °C).*



COURTESY OF
MASCOTT EQUIPMENT COMPANY
Portland Seattle Tri-Cities
www.mascottec.com

