

A B C D E

## Basic Pedestal

## Self Priming Centrifugal Pump

## Models 82H3-B and 82H52-B

## Size 2" x 2"



## PUMP SPECIFICATIONS

**Size:** 2" x 2" (51 mm x 51 mm) NPT - Female.

**Casing:** Gray Iron No. 30.

Maximum Operating Pressure 146 psi (1007 kPa)\*.

**Semi-Open Type, Four Vane Impeller:** Gray Iron No. 30.

Handles 3/4" (19 mm) Diameter Spherical Solids.

**Impeller Shaft:** Carbon Steel No. 1045/1046.

**Shaft Sleeve:** Alloy Steel No. 4130.

**Replaceable Wear Plate:** Carbon Steel No. C1015.

**Pedestal:** Gray Iron No. 30.

**Seal Plate:** Gray Iron No. 30.

**Flap Valve:** Buna-N w/Nylon Reinforcement,  
Gray Iron No. 30 and Steel.

**Radial and Thrust Bearings:** Open Single Row Ball.

**Bearing Lubrication:** SAE No. 30 Non-Detergent Oil.

**Flange:** Gray Iron No. 30.

**Gaskets:** Cork.

**Hardware:** Standard Plated Steel.

**Oil Level Sight Gauge.**

**Optional Equipment:**

90° Discharge Elbow. Strainer

Consult Factory for Additional Options.

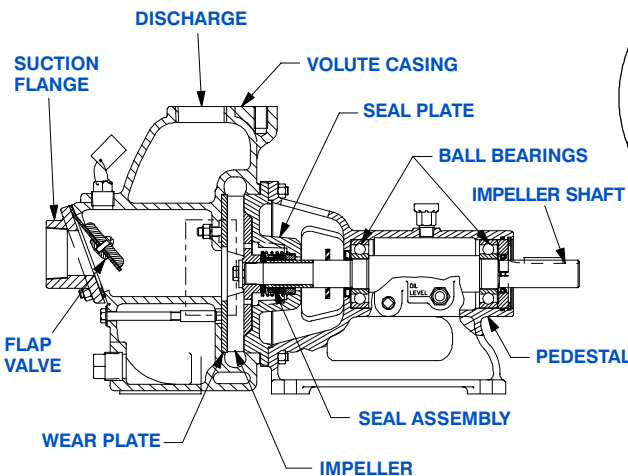

82H3-B SHOWN

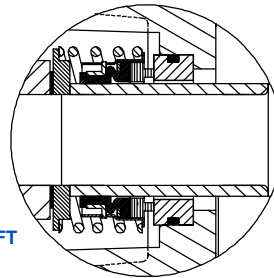

**82H3-B SEAL DETAIL** Type 2, Mechanical, Self-Lubricated. Carbon Rotating Face. Ni-Resist Stationary Face. Fluorocarbon Elastomers. (DuPont Viton® or Equivalent). Stainless Steel No. 18-8 Cage and Spring. Maximum Temperature of Liquid Pumped, 160°F (71 °C).\*

**82H52-B SEAL DETAIL** Type 31, Mechanical, Self-Lubricated. Silicon Carbide Rotating and Stationary Faces. Fluorocarbon Elastomers (DuPont Viton® or Equivalent). Stainless Steel No. 18-8 Cage and Spring. Maximum Temperature of Liquid Pumped 160°F (71°C).\*

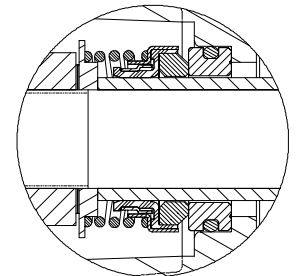

COURTESY OF  
MASCOTT EQUIPMENT COMPANY  
Portland Seattle Tri-Cities  
[www.mascottec.com](http://www.mascottec.com)

Printed in U.S.A.

**Specification Data**

SECTION 50, PAGE 1301

APPROXIMATE  
DIMENSIONS and WEIGHTS

**NET WEIGHT: 120 LBS. (54,4 KG.)**

**SHIPPING WEIGHT: 130 LBS. (58,9 KG.)**

**EXPORT CRATE: 12.5 CU. FT. (0,35 CU. M.)**

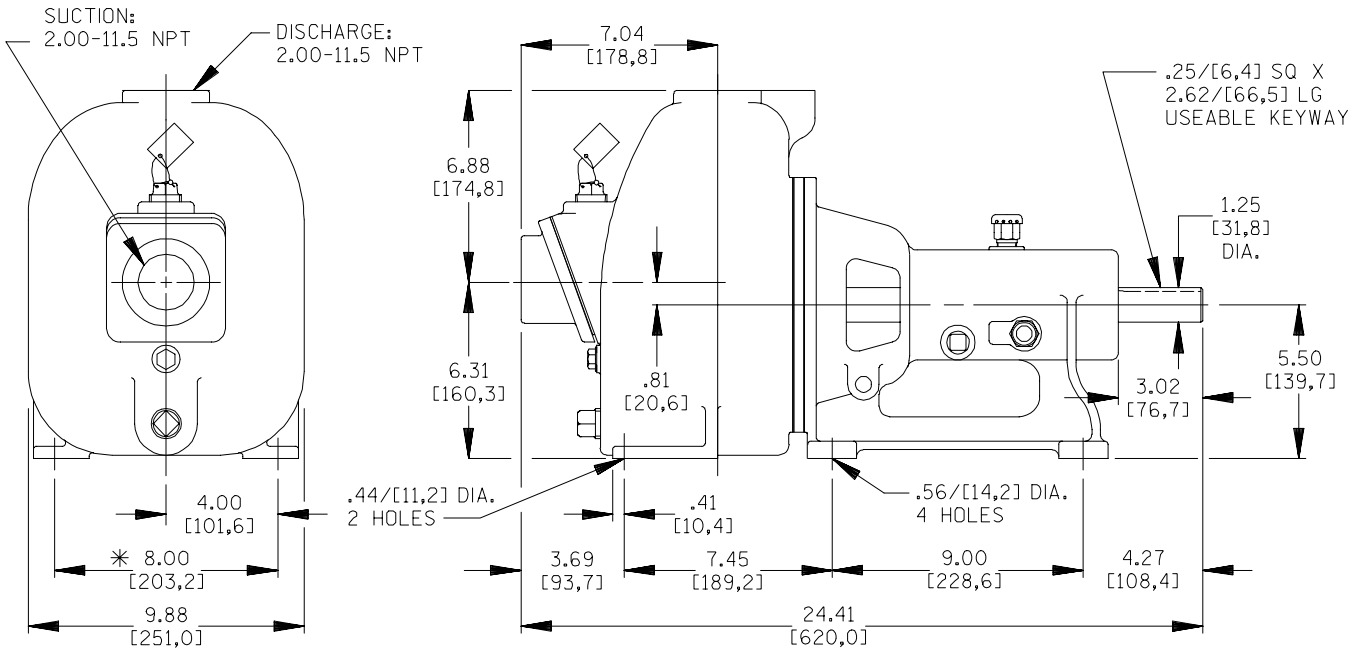

DIMENSIONS:  
INCHES  
[MILLIMETERS]

\* 8.00/[203,2] DISTANCE BETWEEN MOUNTING HOLES APPLIES TO VOLUTE AND PEDESTAL

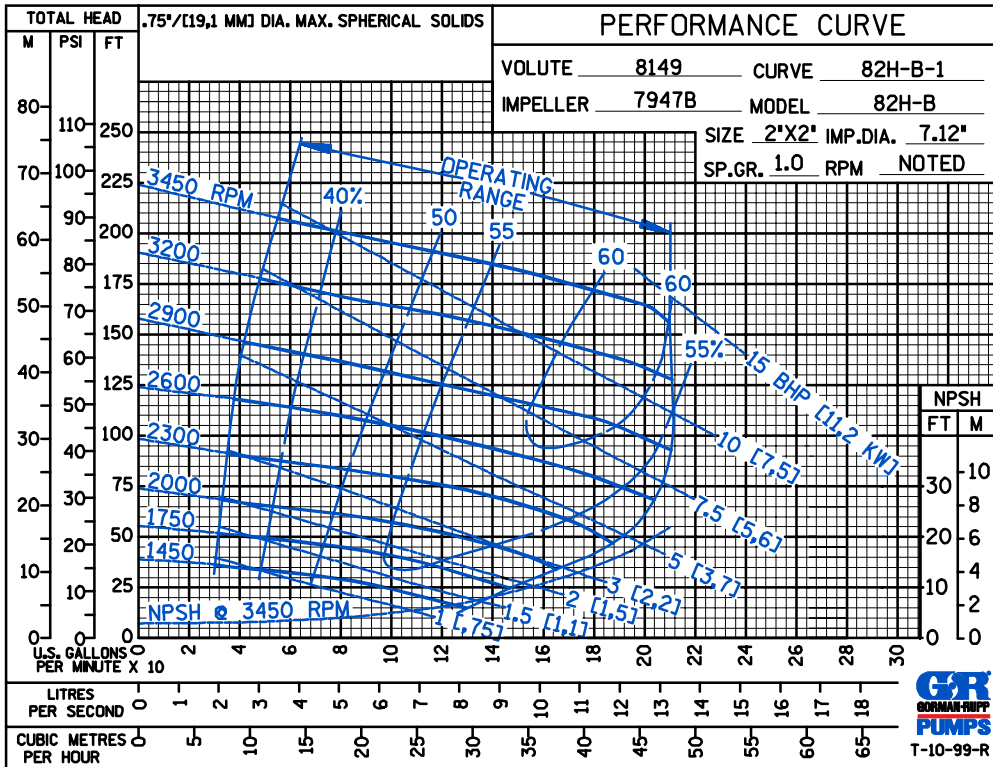

Printed in U.S.A.