

A B C D E

Basic Pedestal

# Self Priming Centrifugal Pump

## Models 84A3-B and 84A52-B

### Size 4" x 4"



**PUMP SPECIFICATIONS**

- Size:** 4" x 4" (102 mm x 102 mm) NPT - Female.
- Casing:** Gray Iron No. 30.  
Maximum Operating Pressure 82 psi (565 kPa)\*.
- Semi-Open Type, Three Vane Impeller:** Gray Iron No. 30.  
Handles 1 1/8" (28,7 mm) Diameter Spherical Solids.
- Impeller Shaft:** Alloy Steel No. 4150.
- Replaceable Wear Plate:** Carbon Steel No. 1015.
- Pedestal:** Gray Iron No. 30.
- Seal Plate:** Gray Iron No. 30.
- Shaft Sleeve:** Alloy Steel No. 4130.
- Flap Valve:** Buna-N and Steel.
- Radial Bearings:** Open Single Row Ball.
- Thrust Bearings:** Open Double Row Ball.
- Bearing Lubrication:** SAE No. 30 Non-Detergent Oil.
- Flanges:** Gray Iron No. 30.
- Gaskets:** Cork.
- O-Rings:** Buna-N
- Hardware:** Standard Plated Steel and Stainless Steel.
- Oil Level Sight Gauge.**
- Optional Equipment:** Consult Factory.



*\*Consult Factory for Applications Exceeding Maximum Pressure and/or Temperature Indicated.*

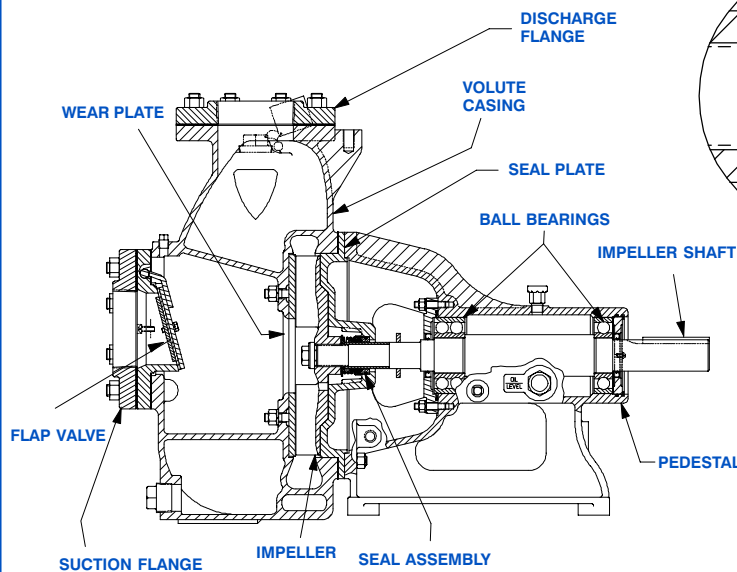

84A3-B SHOWN

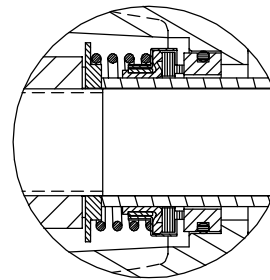

**84A3-B SEAL DETAIL** Type 21, Mechanical, Self-Lubricated. Carbon Rotating Face. Ni-Resist Stationary Face. Fluorocarbon Elastomers (DuPont Viton® or Equivalent). Stainless Steel No. 18-8 Cage and Spring. Maximum Temperature of Liquid Pumped, 160°F (71 °C).\*

**84A52-B SEAL DETAIL**

Type 31, Mechanical, Self-Lubricated. Silicon Carbide Rotating and Stationary Faces. Fluorocarbon Elastomers (DuPont Viton® or Equivalent). Stainless Steel No. 18-8 Cage and Spring. Maximum Temperature of Liquid Pumped 160°F (71°C).\*

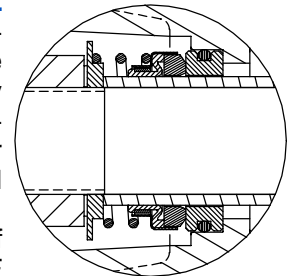

COURTESY OF  
**MASCOTT EQUIPMENT COMPANY**  
Portland Seattle Tri-Cities  
[www.mascottec.com](http://www.mascottec.com)

**Specification Data**

SECTION 50, PAGE 1801

APPROXIMATE  
DIMENSIONS and WEIGHTS

NET WEIGHT: 429 LBS. (160 KGS.)

SHIPPING WEIGHT: 444 LBS. (166 KGS.)

EXPORT CRATE: 18 CU. FT. (0,51 CU. M.)

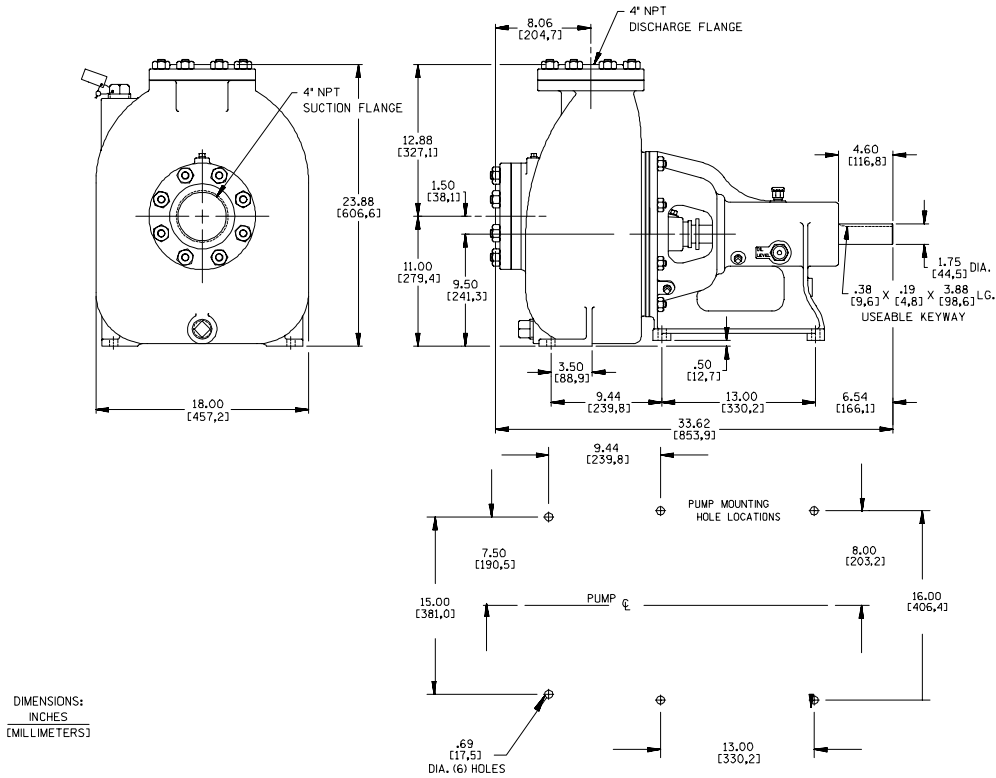

DIMENSIONS:  
INCHES  
(MILLIMETERS)

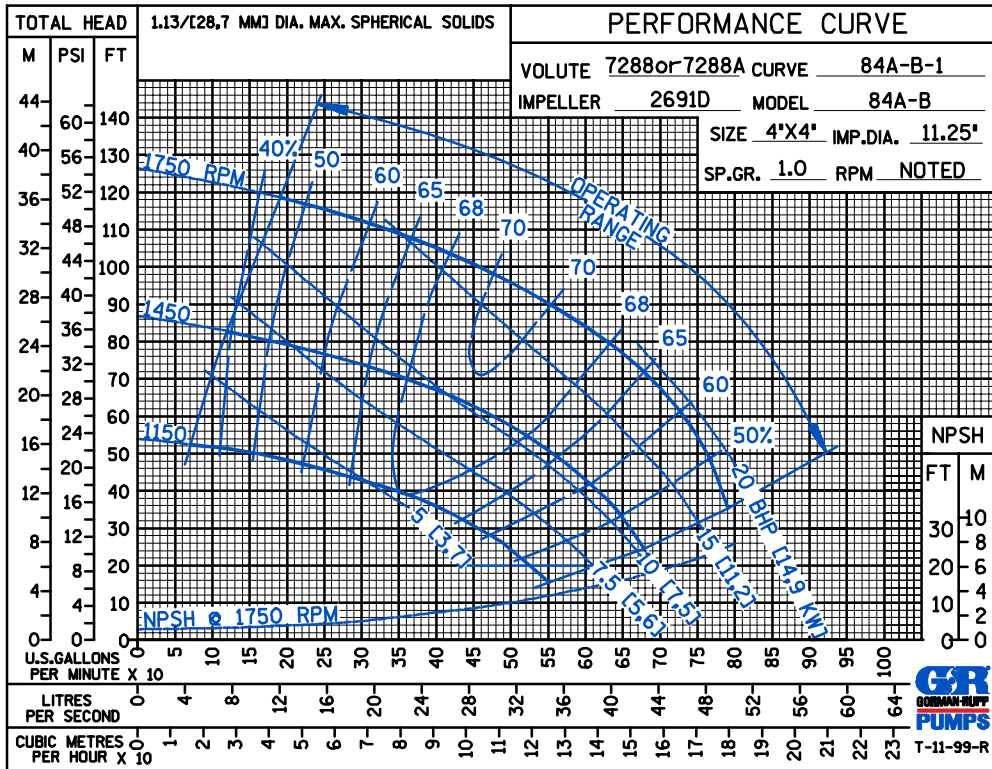

THE GORMAN-RUPP COMPANY • MANSFIELD, OHIO

GORMAN-RUPP OF CANADA LIMITED • ST. THOMAS, ONTARIO, CANADA

Specifications Subject to Change Without Notice

Printed in U.S.A.