

A B C E

Basic Pedestal



Self Priming Centrifugal Pump

Model 03A3-B and 03A20-B

Size 3" x 3"

PUMP SPECIFICATIONS

Size: 3" x 3" (76 mm x 76 mm) NPT - Female.**Casing:** Gray Iron No. 30.

Maximum Operating Pressure 205 psi (1413 kPa).*

Enclosed Type, Six Vane Impeller: Bronze No. C83600

Handles 3/8" (9,5 mm) Diameter Spherical Solids.

Impeller Shaft: Carbon Steel No. 1045.**Replaceable Wear Ring:** Copper Alloy C93200.**Removeable Cleanout Cover:** Gray Iron No. 30 (2 lbs.).**Pedestal:** Gray Iron No. 30.**Seal Plate:** Gray Iron No. 30.**Shaft Sleeve:** Alloy Steel 4130.**Radial Bearing:** Double Ball Type.**Thrust Bearing:** Single Ball Type.**Bearing Lubrication:** SAE No. 30 Non-Detergent Oil.**Flanges:** Gray Iron No. 30.**Gaskets:** Cork ^W/Nitrile Binder NC710.**Hardware:** Standard Plated Steel.**Optional Equipment:** Consult Factory.

**Consult Factory for Applications Exceeding Maximum Pressure and/or Temperature Indicated.*

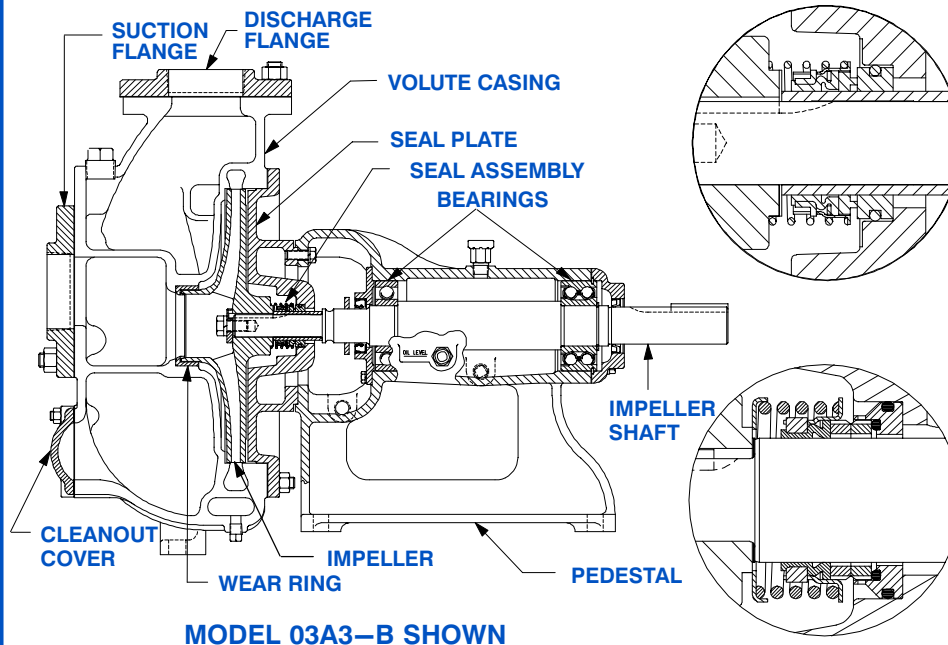

MODEL 03A3-B SHOWN

SEAL MODEL 03A3-B

Type 2 Mechanical Self-Lubricated. Rotating Face is Carbon. Stationary Face is Ni-resist. Fluorocarbon Elastomers (DuPont Viton[®] or Equivalent). Cage and Spring are Stainless Steel No. 18-8. Maximum Temperature of Liquid Pumped, 160°F (71°C).*

SEAL MODEL 03A20-B

Mechanical, Oil-Lubricated, Self-Aligning. Tungsten Titanium Carbide Rotating and Stationary Faces. Stainless Steel No. 316 Stationary Seat. Fluorocarbon Elastomers (DuPont Viton[®] or Equivalent). Stainless Steel Type 18-8 Cage and Spring. Maximum Temperature of Liquid Pumped. 160°F (71°C).*



COURTESY OF
MASCOTT EQUIPMENT COMPANY
Portland Seattle Tri-Cities
www.mascottec.com

Printed in U.S.A.

Specification Data

SECTION 30, PAGE 1600

APPROXIMATE DIMENSIONS and WEIGHTS

NET WEIGHT:
SHIPPING WEIGHTS:
EXPORT CRATE:

306 POUNDS (138 KG)
321 POUNDS (146 KG)
12.2 CUBIC FEET (.34 CU. M.)

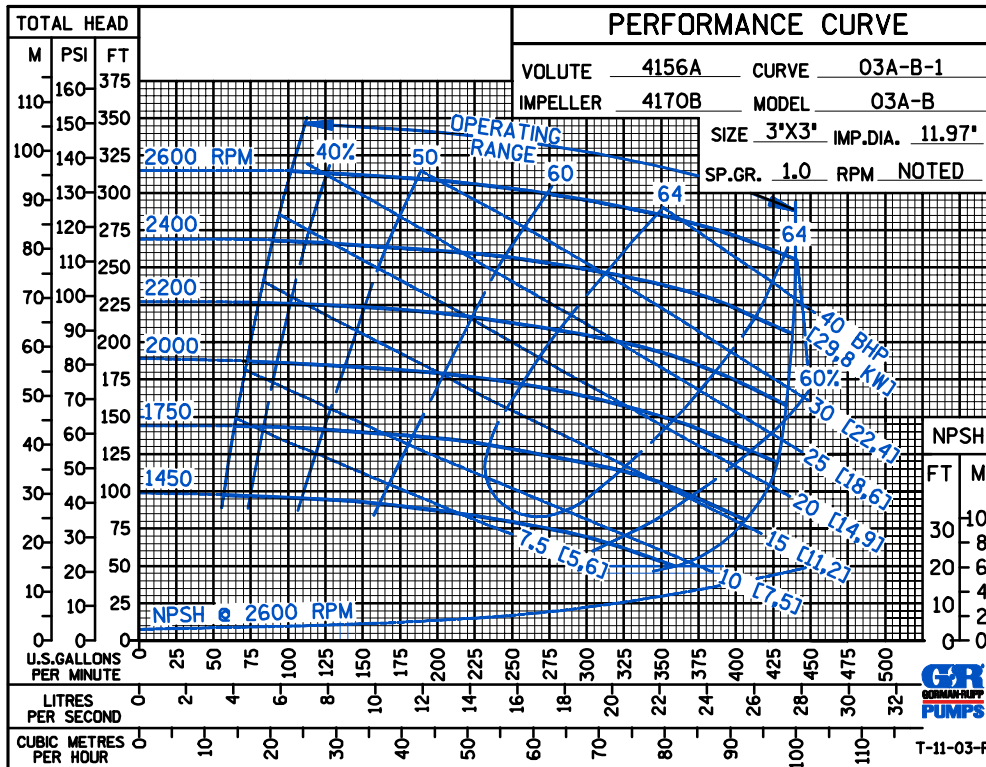
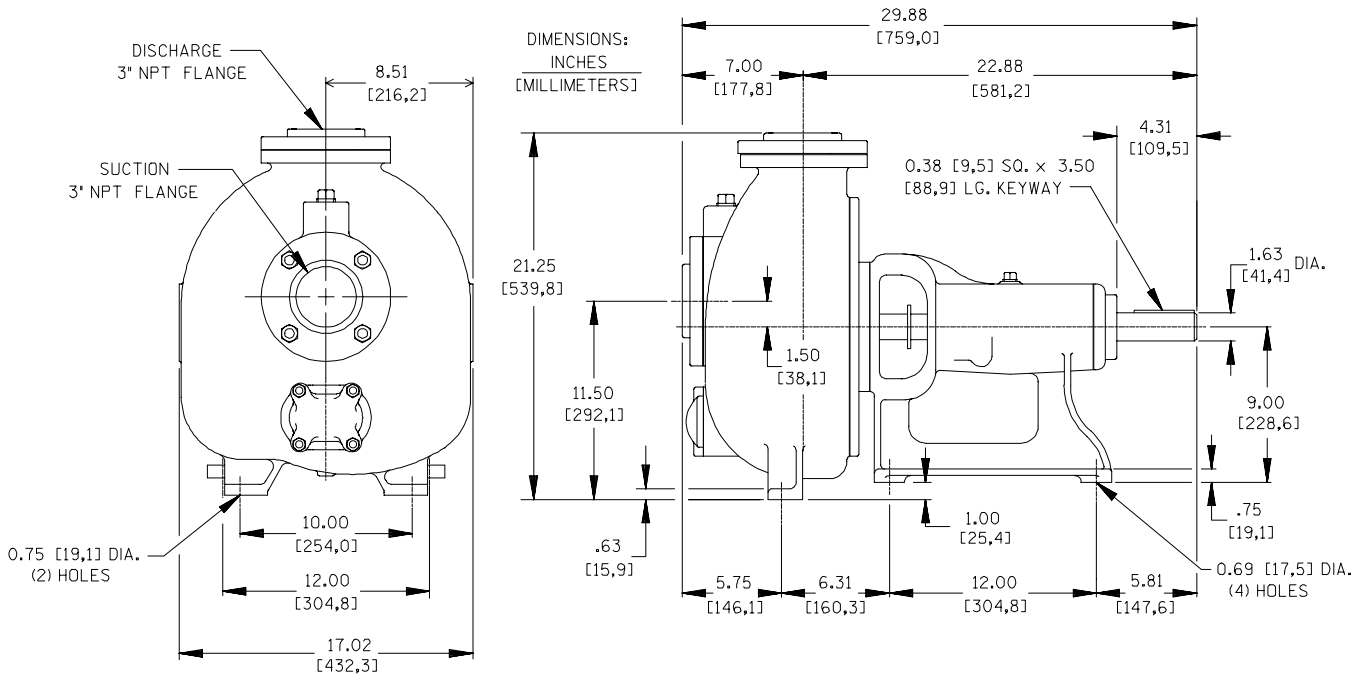

Printed in U.S.A.