

B C

## Basic Pedestal



## Self Priming Centrifugal Pump

Models 03C11-B and 03C31-B

Size 3" x 3"

## PUMP SPECIFICATIONS

**Size:** 3" x 3" (76 mm x 76 mm) NPT - Female.**Casing:** Ductile Iron No. 60-40-18.

Maximum Operating Pressure 75 psi (517 kPa).\*

**Enclosed Type, Five Vane Impeller:** Brass 85-5-5.

Handles 7/16" (11,1 mm) Diameter Spherical Solids.

**Impeller Shaft:** (03C11-B) Stainless Steel No. 303/304.

(03C31-B) Carbon Steel No. 1045.

**Replaceable Vane Plate:** Gray Iron No. 30.**Pedestal:** Gray Iron No. 30.**Seal Plate:** Ductile Iron No. 60-40-18.**Radial and Thrust Bearings:** Single Row Ball Type.**Bearing Lubrication:** Grease.**Flanges:** (03C11-B) Gray Iron No. 30.

(03C31-B) Ductile Iron No. 60-40-18.

**Gaskets:** (03C11-B) PTFE.(03C31-B) Cork <sup>w</sup>/Nitrile Binder NC710.**Hardware:** Standard Plated Steel.**Optional Equipment:** All Iron Construction.

\*Consult Factory for Applications Exceeding Maximum Pressure and/or Temperature Indicated.

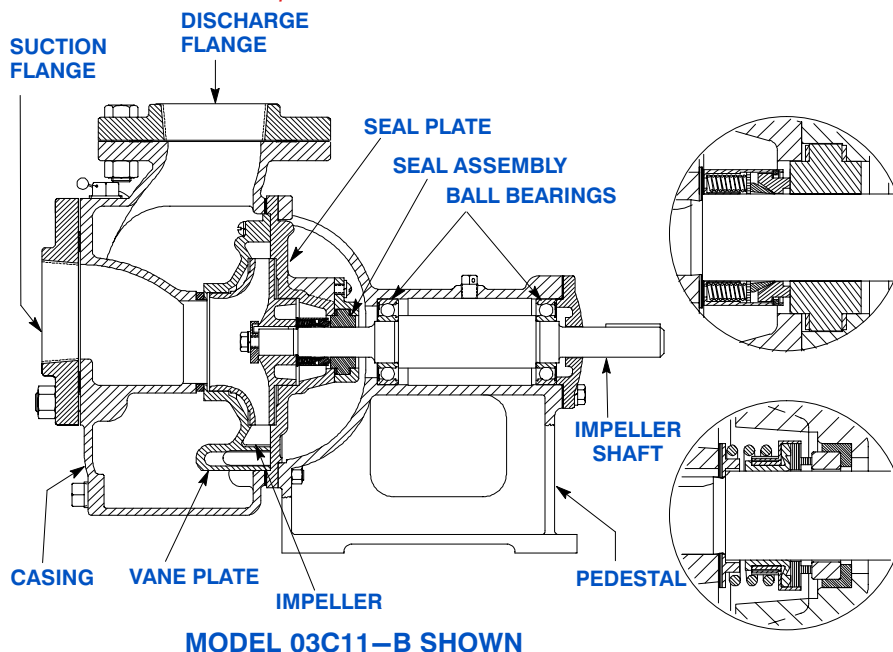
**SEAL MODEL 03C11-B:**

Type 9, Mechanical Self-Lubricated. Rotating Face is Carbon. Stationary Face is Ceramic. PTFE Elastomers. Stainless Steel No. 316 Cage and Spring. Maximum Temperature of Liquid Pumped, 160°F (71°C).\*

**SEAL MODEL 03C31-B:**

Type 21, Mechanical. Self-Lubricated. Carbon Rotating Face. Ni-Resist Stationary Face. Fluorocarbon Elastomers (DuPont Viton® or Equivalent). Stainless Steel No. 18-8 Cage and Spring. Maximum Temperature of Liquid Pumped, 160°F (71°C).\*



COURTESY OF  
**MASCOTT EQUIPMENT COMPANY**  
 Portland Seattle Tri-Cities  
[www.mascottec.com](http://www.mascottec.com)

Printed in U.S.A.

**Specification Data**

SECTION 30, PAGE 1300

APPROXIMATE  
DIMENSIONS and WEIGHTS

**NET WEIGHT:** 122 LBS. (55 KG.)  
**SHIPPING WEIGHT:** 132 LBS. (60 KG.)  
**EXPORT CRATE:** 3.6 CU. FT. (0,1 CU. M.)

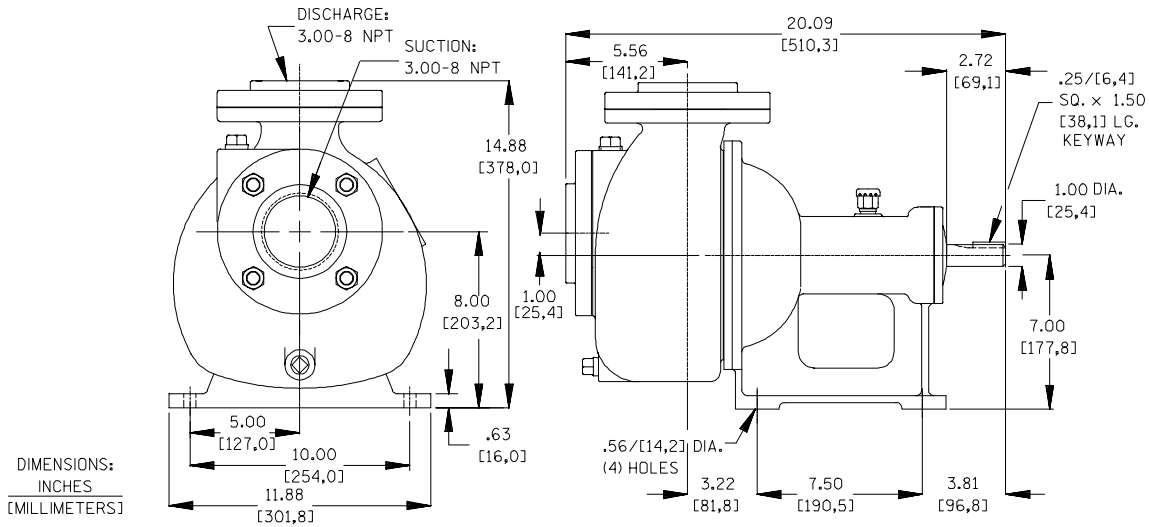

PERFORMANCE  
BASED ON  
WATER

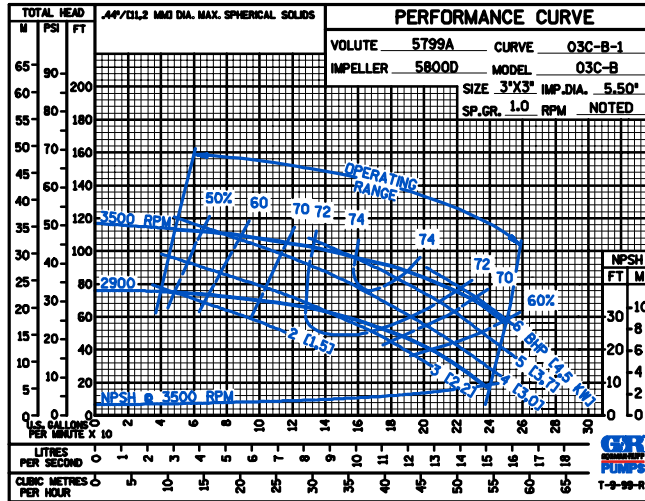

PERFORMANCE  
BASED ON  
PETROLEUM

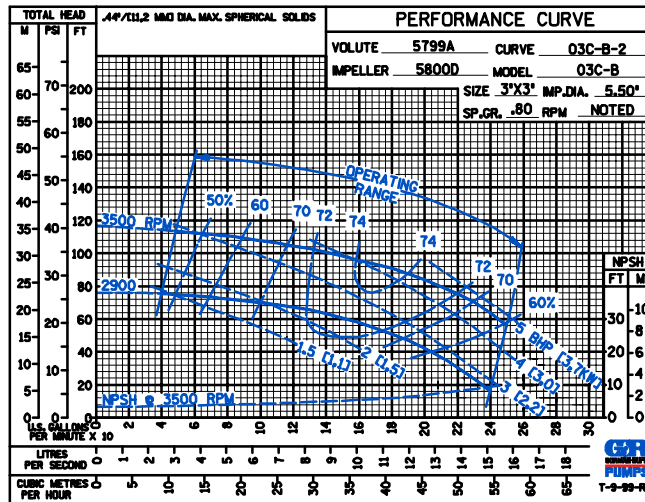

Printed in U.S.A.