

BCE

Basic Pedestal

Self Priming Centrifugal Pump

Model 03F3—B

Size 3" x 3"



PUMP SPECIFICATIONS

Size: 3" x 3" (76 mm x 76 mm) NPT - Female.

Casing: Gray Iron No. 30.

Maximum Operating Pressure 75 psi (517 kPa).*

Enclosed Type, Six Vane Impeller: Copper Alloy C83600.

Handles 5/8" (15,9 mm) Diameter Spherical Solids.

Impeller Shaft: Alloy Steel No. 4150.

Replaceable Wear Ring: Gray Iron No. 30.

Pedestal: Gray Iron No. 30.

Seal Plate: Gray Iron No. 30.

Shaft Sleeve: Alloy Steel No. 4130.

Radial Bearing: Open Single Row Ball.

Thrust Bearing: Open Double Row Ball.

Bearing Lubrication: Grease.

Flanges: Gray Iron No. 30.

Gaskets: Composition Cork and Buna-N.

Hardware: Standard Plated Steel.

Optional Equipment: All Iron Construction. Fluorocarbon Gaskets (DuPont Viton® or Equivalent). Gray Iron No. 30 Spool Flanges.

**Consult Factory for Applications Exceeding Maximum Pressure and/or Temperature Indicated.*

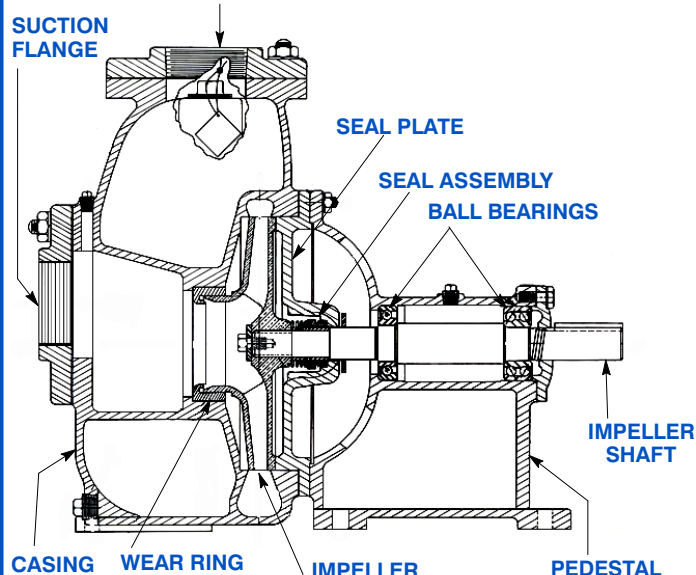

SEAL DETAIL

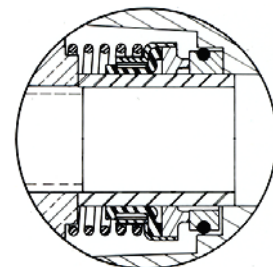

SEAL SPECIFICATIONS:

Type 21, Mechanical Self-Lubricated. Carbon Rotating Face. Ni-Resist Stationary Face. Fluorocarbon Elastomers (DuPont Viton® or Equivalent). Stainless Steel No. 18-8 Cage and Spring. Maximum Temperature of Liquid Pumped, 160°F (71°C).*



COURTESY OF
MASCOTT EQUIPMENT COMPANY
 Portland Seattle Tri-Cities
www.mascottec.com

Printed in U.S.A.

Specification Data

SECTION 30, PAGE 1500

APPROXIMATE
DIMENSIONS and WEIGHTS

NET WEIGHT:
SHIPPING WEIGHTS:
EXPORT CRATE:

199 LBS (90,2 KGS.)
209 LBS (94,8 KGS.)
8.6 CU. FT. (0,24 CU. M.)

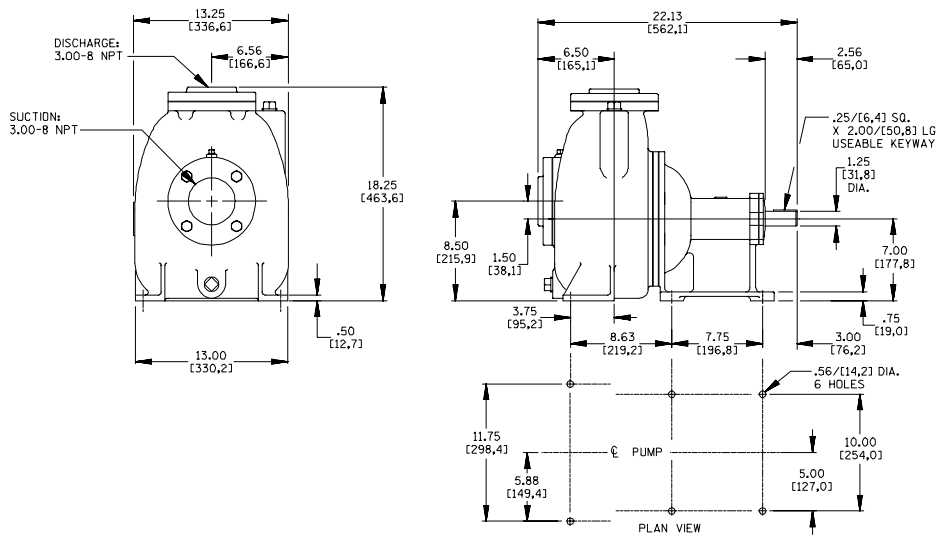

DIMENSIONS:
INCHES
(MILLIMETERS)

**PERFORMANCE
BASED ON
WATER**

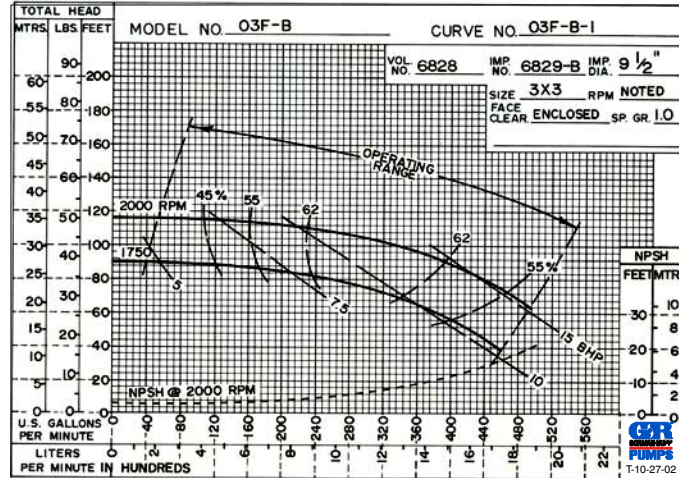

**PERFORMANCE
BASED ON
PETROLEUM**

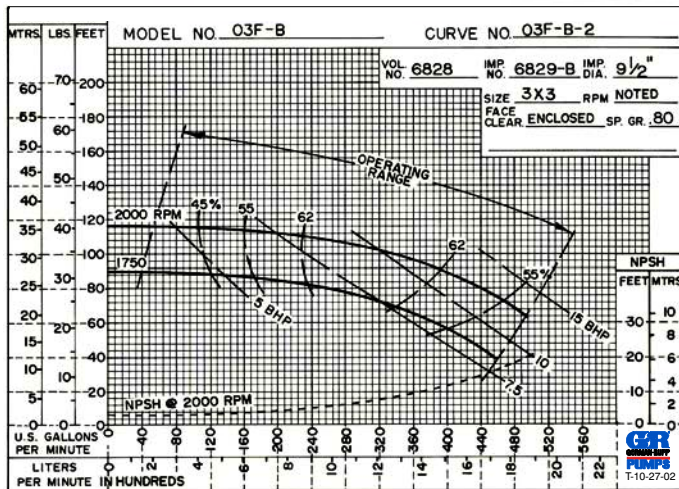

Printed in U.S.A.