

ABCE



# Basic Pedestal

## Self Priming Centrifugal Pump

### Models 04A3-B and 04A20-B

### Size 4" x 4"

**PUMP SPECIFICATIONS**

- Size:** 4" x 4" (102 mm x 102 mm) NPT – Female
- Pump Casing:** Gray Iron No. 30.  
Maximum Operating Pressure 235 psi (1623 kPa).\*
- Enclosed Type, Five Vane Impeller:**  
(04A3-B): Copper Alloy C83600.  
(04A20-B): Gray Iron No. 30.  
Handles 9/16" (14,3 mm) Diameter Spherical Solids.
- Impeller Shaft:** Carbon Steel Grade 1045.
- Shaft Sleeve:** (04A3-B) Alloy Steel No. 4130.
- Replaceable Wear Rings:** Gray Iron No. 30.
- Removable Cleanout Cover:** Gray Iron No. 30.  
Weight 2 lbs. (0,9 kg.).
- Pedestal:** Gray Iron No. 30.
- Seal Plate:** Gray Iron No. 30.
- Radial Bearing:** Open Single Row Ball.
- Thrust Bearing:** Open Double Row Ball.
- Bearing Lubrication:** SAE No. 30 Non-Detergent Oil.
- Flanges:** Ductile Iron No. 60-40-18.
- O-Rings:** Buna-N.
- Gaskets:** Resistant Synthetic Rubber and Cork.
- Hardware:** Standard Plated Steel.
- Oil Level Sight Gauge.**
- Optional Equipment:** Strainer.



*\*Consult Factory for Applications Exceeding Maximum Pressure and/or Temperature Indicated.*

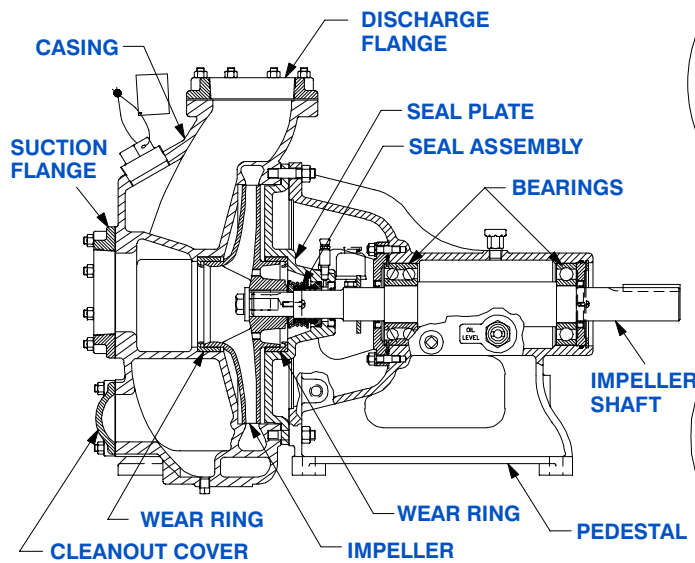

MODEL 04A20-B SHOWN

**SEAL MODEL 04A3-B**

Type 2, Mechanical, Self-Lubricated. Carbon Rotating Face. Ni-Resist Stationary Face. Fluorocarbon Elastomers (DuPont Viton® or Equivalent). Stainless Steel No. 18-8 Cage and Spring. Maximum Temperature of Liquid Pumped 160°F (71°C).\*

**SEAL MODEL 04A20-B**

Type 2, Mechanical, Oil-Lubricated, Self-Aligning. Tungsten Titanium Carbide Rotating and Stationary Faces. Stainless Steel Type 316 Stationary Seat. Fluorocarbon, Elastomers (DuPont Viton® or Equivalent). Stainless Steel 18-8 Cage and Spring. Maximum Temperature of Liquid Pumped, 160°F (71°C).\*



COURTESY OF  
**MASCOTT EQUIPMENT COMPANY**  
Portland Seattle Tri-Cities  
[www.mascottec.com](http://www.mascottec.com)

**Specification Data**

**SECTION 30, PAGE 1700**

APPROXIMATE  
DIMENSIONS and WEIGHTS

**NET WEIGHT: 365 LBS. [166 KG.]**  
**SHIPPING WEIGHT: 388 LBS. [176 KG.]**  
**EXPORT CRATE: 12.2 CU. FT. [.34 CU. M.]**

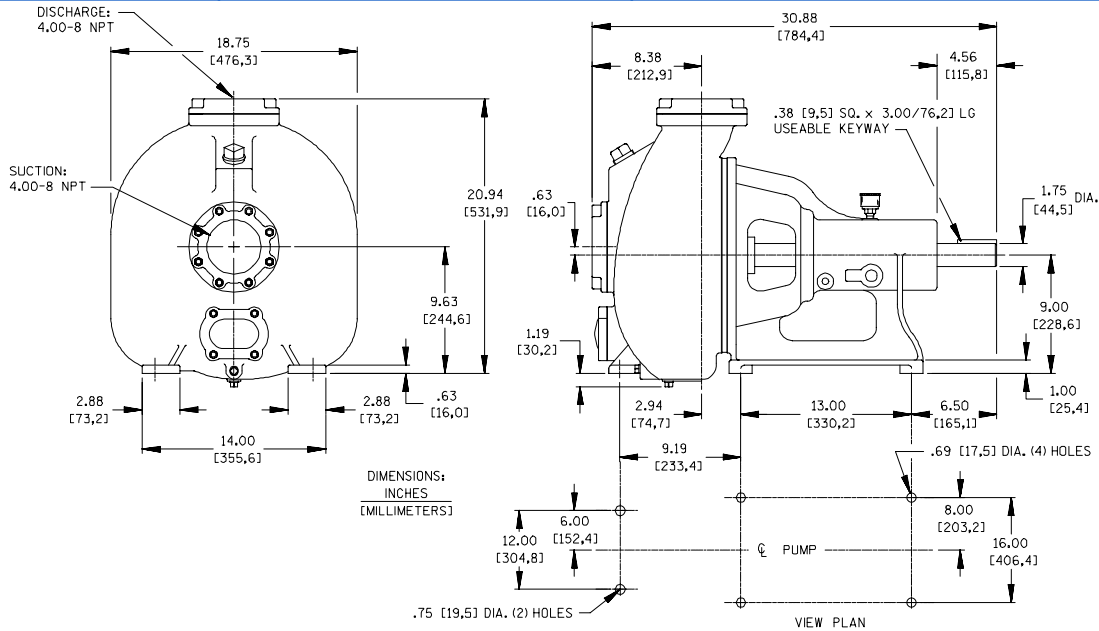

**PERFORMANCE  
BASED ON  
PETROLEUM**

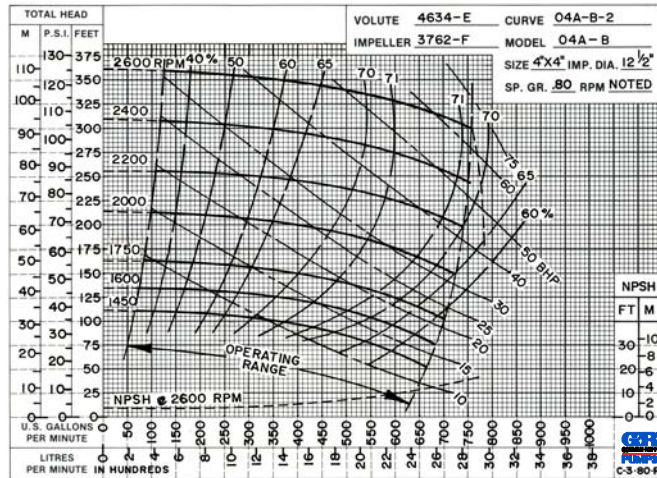

**PERFORMANCE  
BASED ON  
WATER**

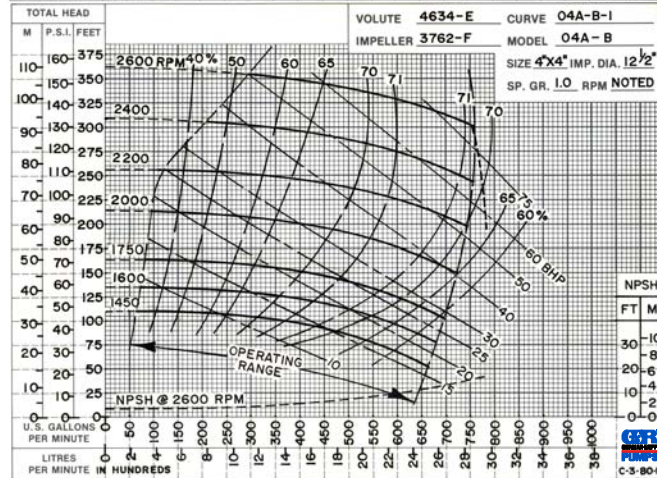

Printed in U.S.A.