

BCE

Basic Pedestal

Self Priming Centrifugal Pump

Model 04C3-B

Size 4" x 4"



PUMP SPECIFICATIONS

Size: 4" x 4" (102 mm x 102 mm) NPT – Female.

Casing: Gray Iron No. 30.

Maximum Operating Pressure 130 psi (897 kPa).*

Enclosed Type, Six Vane Impeller: Copper Alloy C83600.

Handles 11/16" (17,5 mm) Diameter Spherical Solids.

Impeller Shaft: Alloy Steel No. 4150.

Replaceable Wear Rings: Copper Alloy C83600.

Pedestal: Gray Iron No. 30.

Seal Plate: Gray Iron No. 30.

Shaft Sleeve: Alloy Steel 4130.

Radial Bearing: Single Row Ball Type.

Thrust Bearing: Double Row Ball Type.

Bearing Lubrication: Grease.

Flanges: Ductile Iron No. 60-40-18.

Gaskets: Cork ^w/Nitrile Binder NC710.

Hardware: Standard Plated Steel.

Consult Factory for Applications Exceeding Maximum Pressure and/or Temperature Indicated.

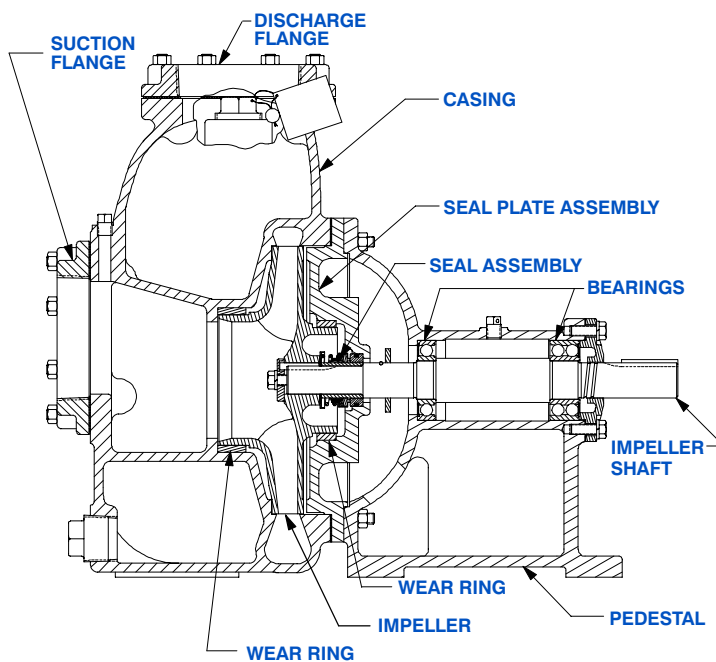

SEAL DETAIL

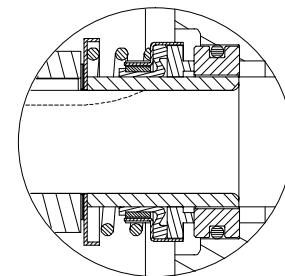

SEAL SPECIFICATIONS

Type 21, Mechanical Self-Lubricated. Carbon Rotating Face. Ni-Resist Stationary Face. Fluorocarbon Elastomers (DuPont Viton[®] or Equivalent). Cage and Spring are Stainless Steel No. 18-8. Maximum Temperature of Liquid Pumped, 160°F [71°C].*



COURTESY OF
MASCOTT EQUIPMENT COMPANY

Portland Seattle Tri-Cities

www.mascottec.com

Printed in U.S.A.

Specification Data

SECTION 30, PAGE 1850

APPROXIMATE
DIMENSIONS and WEIGHTS

NET WEIGHT:
SHIPPING WEIGHTS:
EXPORT CRATE:

193 LBS. (88 KG.)
203 LBS. (92 KG.)
8.6 CU. FT. (0,24 CU. M.)

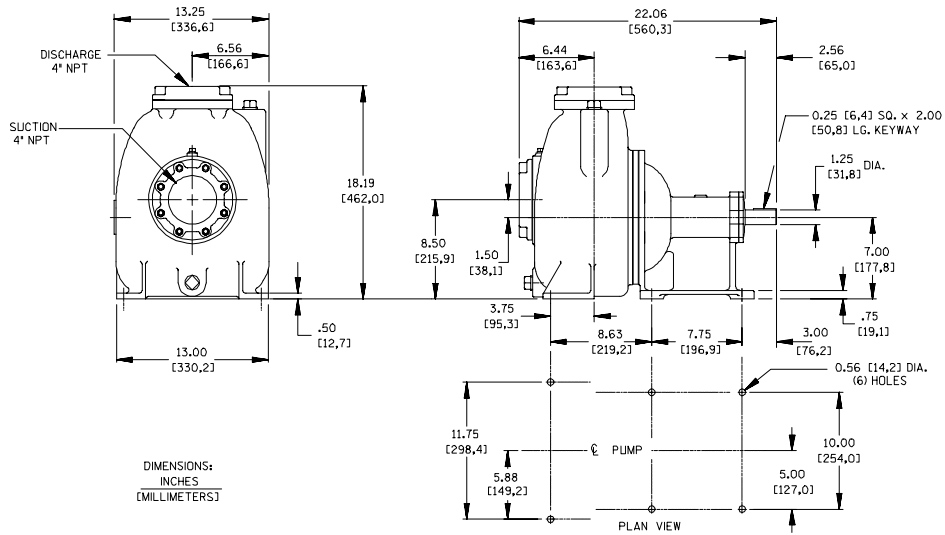

**PERFORMANCE
BASED ON
WATER**

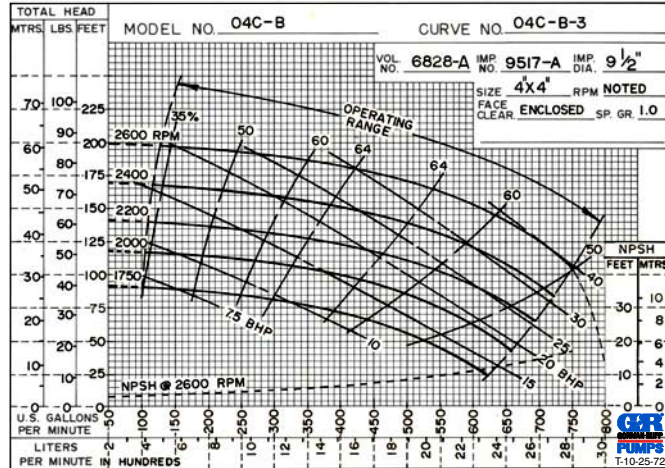

**PERFORMANCE
BASED ON
PETROLEUM**

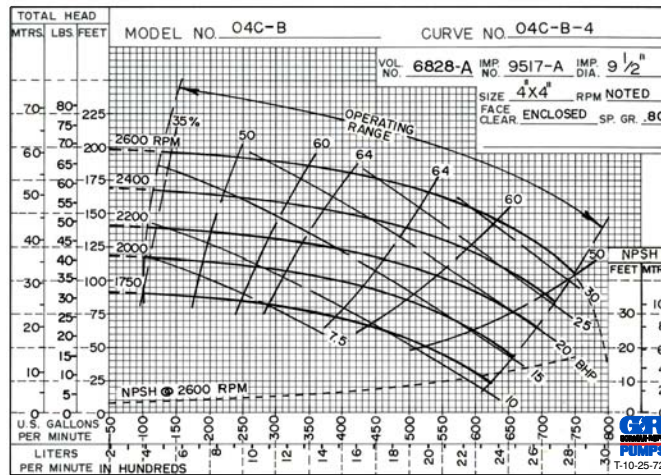

Printed in U.S.A.