

B

Basic Pump



Self Priming Centrifugal Pump

Models RD4A31 – B and RD4A32 – B

Size 6" x 4"

PUMP SPECIFICATIONS

Size: 6" x 4" (152mm x 102 mm) Flanged.
 Casing: (RD4A31-B) Ductile Iron No. 65-45-12.
 (RD4A32-B) Cast Steel 70-36.
 Maximum Operating Pressure 203 PSI (1386 kPa).
 Enclosed Type, Five Vane Impeller: Aluminum 356-T6.
 Handles 1/2" (12,7 mm) Diameter Spherical Solids.
 Impeller Shaft: Steel No.1045.
 Rotor: Copper Alloy C93400.
 Bearing Housing: Ductile Iron No. 65-45-12.
 Body Cover: (RD4A31-B) Ductile Iron No. 65-45-12.
 (RD4A32-B) Cast Steel 70-36.
 Center/Spacer Plate: (RD4A31-B) Ductile Iron No. 65-45-12.
 (RD4A32-B) Cast Steel 70-36.
 Radial Bearing: Open Double Row Ball Type.
 Thrust Bearing: Open Single Row Ball Type.
 Bearing Lubrication: SAE No. 30 Non-Detergent Oil.
 Gaskets: Vegetable Fiber, PTFE and Cork.
 Priming: Rotary Vane Type with Built-in Spring-Loaded Priming Assist Valve.
 Optional Equipment: Stainless Steel No. 416 Impeller Shaft, Buna-N Seal,
 PTFE Seal with Fluorocarbon O-Ring, PTFE Seal with Buna-N O-Ring, S-
 tandard 4" Check Valve (Required for Priming).
 *Consult Factory for Applications Exceeding Maximum Pressure and/or
 Temperature Indicated.

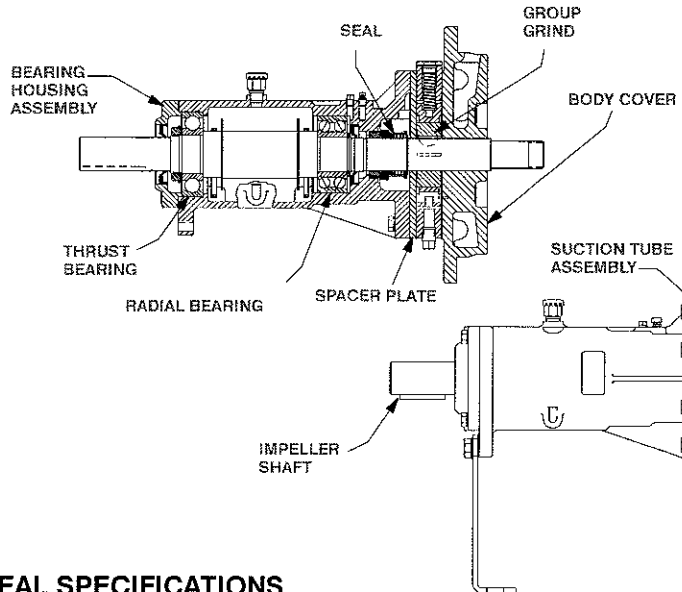
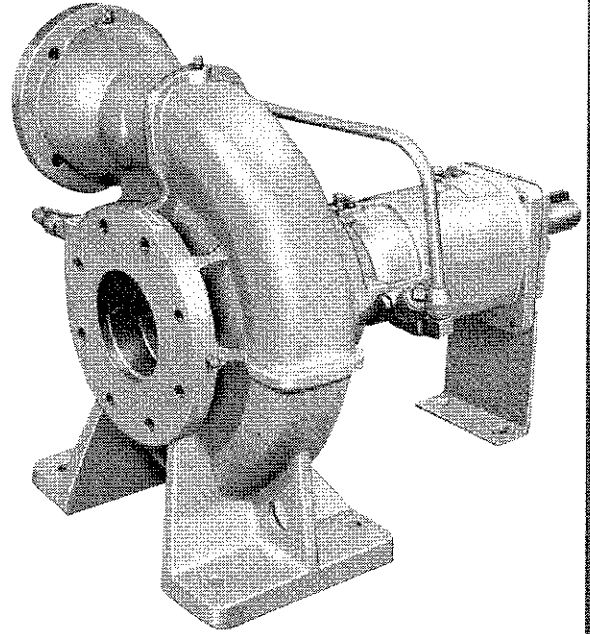

CAUTION
 This Is Not A Water Pump. Use For Petroleum Products Only.

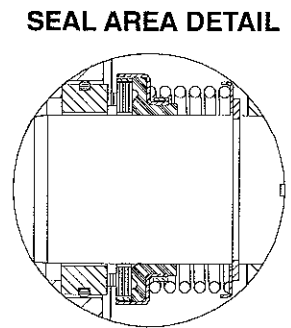

SEAL SPECIFICATIONS

Seal: Mechanical; Self-Lubricated. Fluorocarbon Elastomers (DuPont Viton® or Equivalent). Carbon Rotating Face; Ni-Resist Stationary Face; Maximum Temperature of Liquid Pumped is 160°F (71°C).*



COURTESY OF
MASCOTT EQUIPMENT COMPANY
 Portland Seattle Tri-Cities
www.mascottec.com

Printed in U.S.A.

Specification Data

SECTION 35, PAGE 500

OVERALL DIMENSIONS
and
APPROXIMATE WEIGHTS

RD4A31-B

RD4A32-B

PUMP NET WEIGHT: 326 LBS. (147,9 KG.) 348 LBS. (157,9 KG.)
 SHIPPING NET WEIGHT: 346 LBS. (156,9 KG.) 363 LBS. (164,7 KG.)
 EXPORT CRATE SIZE: 18 CU. FT. (0,51 CU. M.)

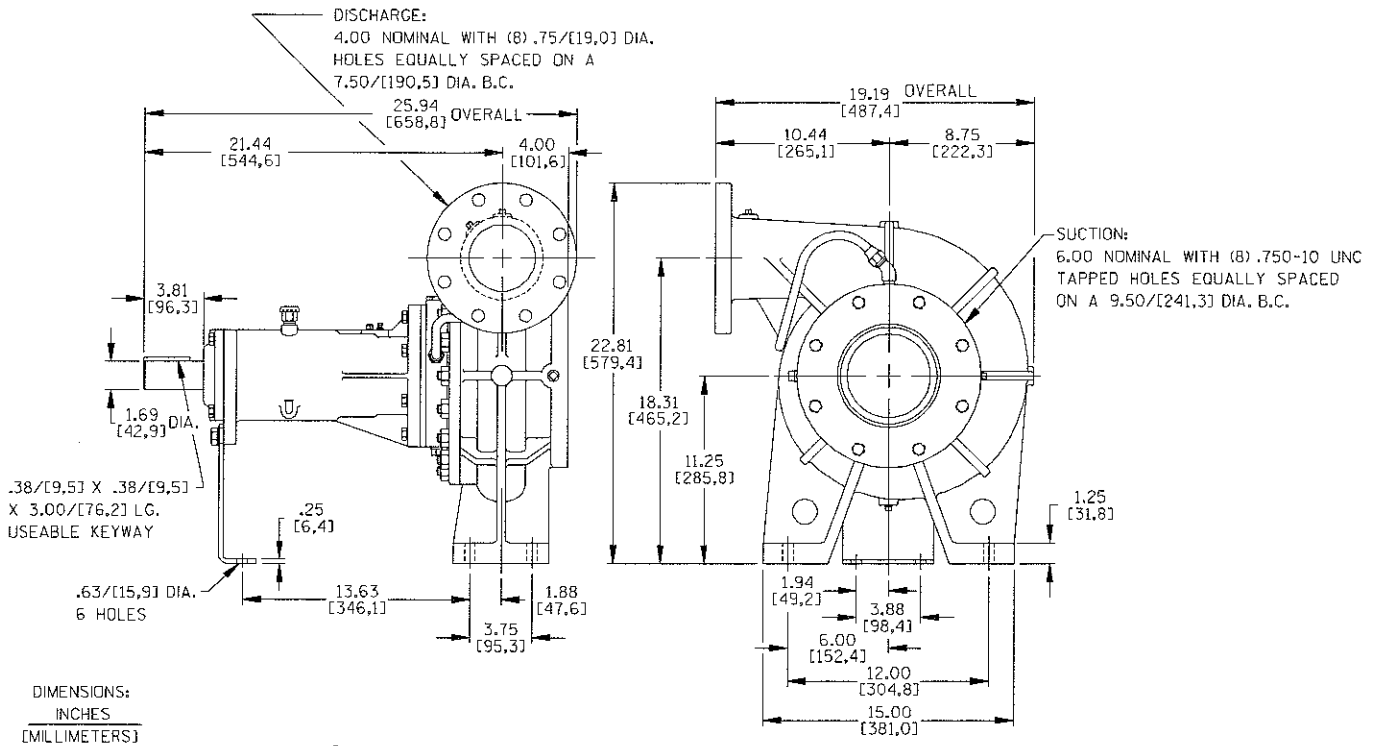

Air Release Valve Required When Static Discharge Pressure Exceeds 8 psi (55 kPa).

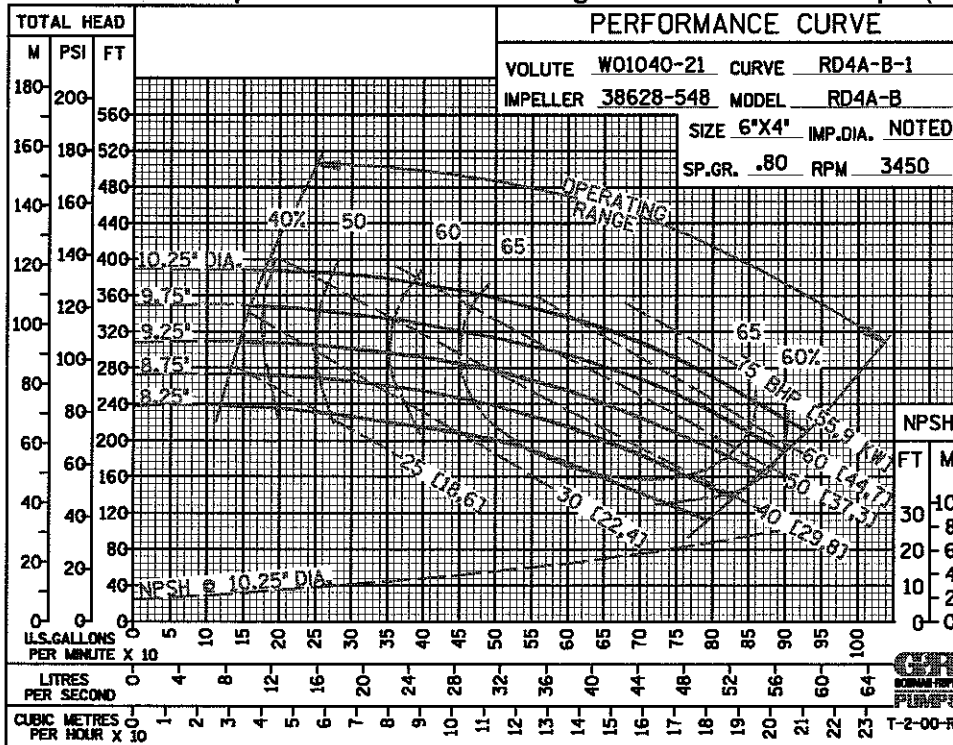

THE GORMAN-RUPP COMPANY • MANSFIELD, OHIO

GORMAN-RUPP OF CANADA LIMITED • ST. THOMAS, ONTARIO, CANADA

Specifications Subject to Change Without Notice

Printed in U.S.A.