



Specifications

M-15 Meters



Liquid Controls M and MA Series rotary motion positive displacement (PD) meters offer the ultimate in measurement accuracy for custody transfer of petroleum products, aviation fuels, LPG, and a broad range of industrial liquids.

Superior performance features

Low pressure drop - will operate on gravity flow or pump pressure.

Sustained accuracy - no metal-to-metal contact inside the measuring chamber means minimal wear and deterioration in accuracy over time, fewer recalibrations, and longer service life. Meters conform to NIST and International Weights and Measures accuracy requirements.

Wide viscosity range - LC meters can accurately meter products from less than 30 SSU (less than 1 centipoise) to 1,500,000 SSU (325,000 centipoise).

Maximum adaptability - choice of stock or custom elbows/fittings provides unequaled mounting flexibility to meet widely varying installation requirements.

Industries served

LC M and MA series meters are well suited for use in industries requiring precise flow measurement and reliable, extended service life:

- Refined petroleum products
- Aviation fuels
- LPG
- Agricultural chemicals
- Paints and coatings
- Foods and beverages
- Petrochemicals
- Pharmaceuticals
- Cosmetics
- Printing Inks
- Textiles

Accuracy/Performance*

Repeatability

Mechanical registration: capable of 0.05% of reading over entire range

Electronic registration: capable of 0.03% of reading over entire range

Linearity

Over 5:1 range

Mech. registration: capable of $\pm 0.125\%$ or better from max. nom. flow rate

Elect. registration: capable of $\pm 0.10\%$ or better from max. nom. flow rate

Over 10:1 range

Mech. registration: capable of $\pm 0.22\%$ or better from max. nom. flow rate

Elect. registration: capable of $\pm 0.10\%$ or better from max. nom. flow rate

Over 40:1 range

Mech. registration: capable of $\pm 0.5\%$ or better from max. nom. flow rate

Elect. registration: capable of $\pm 0.15\%$ or better from max. nom. flow rate

Temperature range

-40° F to 160° F (-40° C to 71° C)

*Stated accuracy obtainable when all variables remain constant. Reading/measurements reflect a minimum of one minute of flow at selected rate(s). All accuracy statements based on metering safety solvent (aliphatic hydrocarbon), approximate viscosity 1 CPS. On higher viscosity products, the average deviation in accuracy will be less.

Construction

Meter housing and rotors

Cast aluminum (other metalurgies available including brass, cast-iron and stainless steel)

Internal components

Aluminum, Ni-Resist, stainless steel

Seal materials

UL recognized component: Buna-N, Viton®, Teflon®¹

Bearings

Carbon, Teflon, Ni-Resist

¹Viton and Teflon are registered trademarks of DuPont Corporation.

Front View

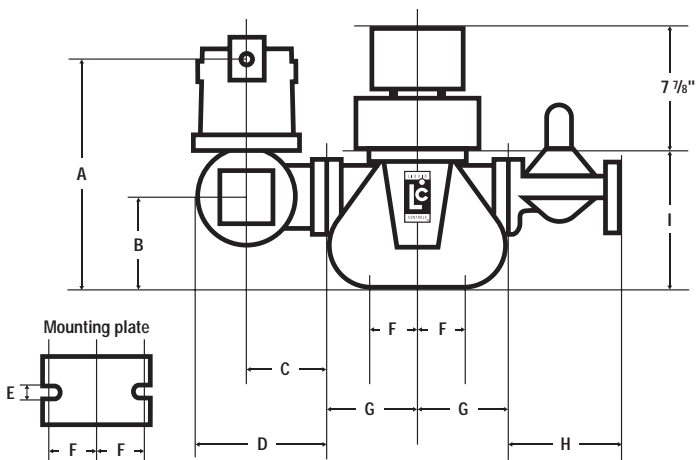

Top View

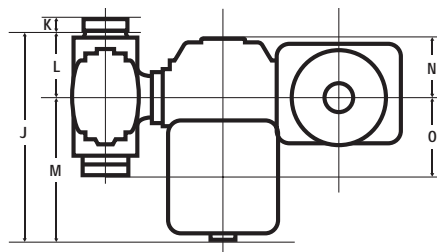

Dimensions: flow meters with electronic registration

Note: Dimensions shown are not for construction use.
Consult factory when certified engineering prints are required.

Model	Flange size	Max. nom. Flow rate	Working pressure	Dimensions																Net Wt
				A	B	C	D	E	F	G	H	I	J	K	L	M	N	O		
M-15	3" or 3" in, 2" out	200 GPM (760 L/min)	150 PSI (10.5 BAR)	in	17	7.5	5	7.7	0.69	3.8	5.5	12	10.8	16.1	1.3	5	11.1	5.1	6.5	37 lbs (16.8 kg)
				mm	432	191	127	195	17	95	140	291	273	410	32	127	238	129	165	

Ordering Information

Model : _____ - _____ - _____ - _____

Description : _____

Flow rates: Max. _____ Normal _____ Min. _____

Operating temperatures: Max. _____ Normal _____ Min. _____

Maximum non-shock operating pressure: _____

Maximum viscosity: _____ @ _____ (Temp°/F or C)

Specific gravity: _____ @ _____ (Temp°/F or C)

Construction class: (1, 2, etc.) _____

Seal material: Standard Buna/Viton All Viton All Teflon

Direction of flow: L to R R to L

Read out: Gallons Liters Pounds Other _____

Mechanical counter and printer: Zero/Face up Zero/Face down Accumulative

Strainer basket : 40M 80M 100M Other _____

Flange size: _____

Flange type: NPT BSPT Slip weld ANSI DIN Other _____

Options: _____

Class	Description	Bearing Material
1	Refined petroleum products	Ni-Resist ¹
2	Aviation and jet fuel	Ni-Resist ¹
3	Variety of products includes: liquid sugars, sweeteners, syrups, vegetable oils	Ni-Resist ¹
4	Treated waters and solvents where no red metals are allowed	Carbon
14	Crude oil	Ni-Resist
15	Oil - or water-bases latex products, polyester resins, adhesives, herbicides, nitrogen fertilizers	Teflon
16	General solvents	Carbon

¹ Carbon bearings are standard on some meter sizes of this class. Consult factory.

COURTESY OF
MASCOTT EQUIPMENT COMPANY
Portland Seattle Tri-Cities
www.mascottec.com



LIQUID CONTROLS
A Unit of IDEX Corporation

© 2003 Liquid Controls
(07/03)

