

9095A 3" AST Overfill Prevention Valve

Description

The 9095A AST Overfill Prevention Valve is installed at the fill port of a top loading aboveground storage tank. Used in a tight fill application, the valve terminates flow of product when the liquid level reaches a pre-set warning level (90-95% full). The valve is installed through a 6" riser pipe or 6" bunghole when used with the tight fill adaptor. When installed to manufacturers requirements, the Morrison Fig. 9095A Overfill Prevention Valve can eliminate environmentally hazardous spills.

This valve complies with the following codes:

NFPA 30, 30A, UFC, BOCA, SBCCI/SFC, and PEI RP2000

Product Warnings and Cautions

- **Read all warnings, cautions, and instructions completely before installation.**
- Minimum flow requirements for valve operation: 5 GPM inlet flow at 5 PSI inlet pressure.
- Maximum rating of valve is 300 GPM at 100 PSI.
- Maximum allowable viscosity is 60 centistokes.
- A tight fill is required for the valve to operate. Do not substitute any other fill adaptors for the special adaptor supplied.
- The valve should be properly inspected before installation to insure the unit was not damaged during the delivery process.
- Use caution during installation to protect float devices and their linkage. Damage to these parts may cause the valve to function improperly.
- The valve must be used with clean product. Debris from products such as contaminated waste oil may cause the valve to function improperly.
- Consult Morrison Brothers Co. for product compatibility with the valve.
- **Failure to follow any or all of the above warnings may render the valve nonfunctional and could result in a hazardous product spill, which may result in personal injury, property damage, fire, explosion, or environmental contamination.**

Filling Procedure

- 1) Make sure the fill nozzle is equipped with the appropriate coupler to form a secure connection with the tight fill adaptor.
- 2) Attach the nozzle to the tight fill adaptor making sure the connection is secure.
- 3) Switch on the pumping system.
- 4) Open the fill nozzle and begin product transfer.
- 5) Continually monitor the liquid level measurement device during the fill.
- 6) Watch for a slight movement of the fill hose or listen for pump bypass activation which indicates overfill shut-off.

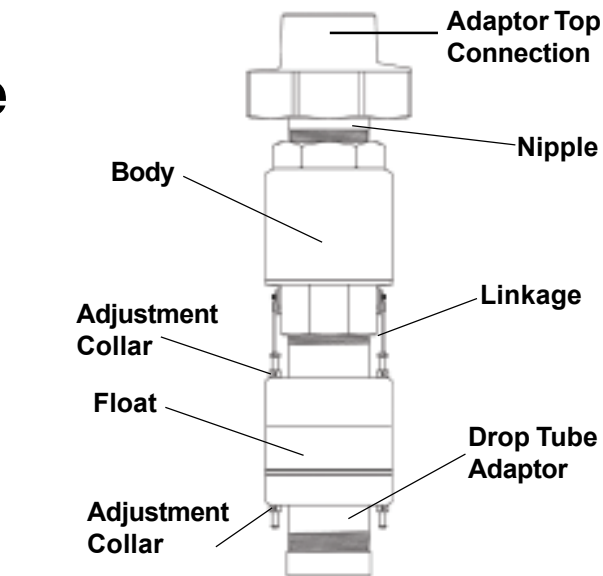

	CONNECTION	
	Adaptor Top-Female	Adaptor Bottom-Female
9095A-3300 AV	3"- 8 NPT	6"- 8 NPT
9095A-AV3300 AV	3"- 8 NPT	6"- 8 NPT

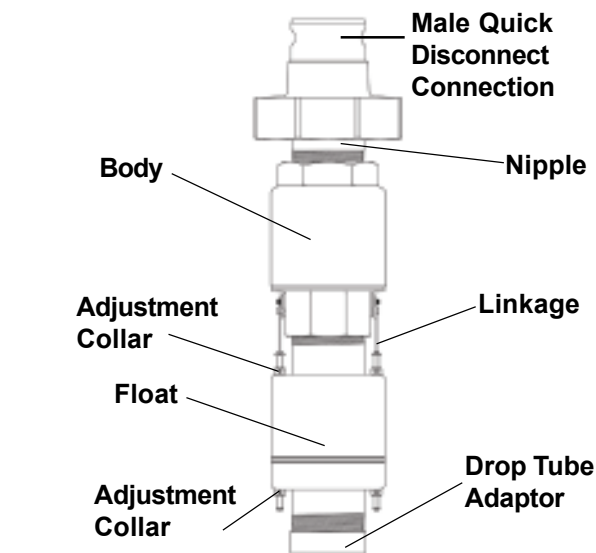

	CONNECTION	
	Male Quick Disconnect	Adaptor Bottom-Female
9095A-0300 AV	3"	6"- 8 NPT
9095A-AV0300 AV	3"	6"- 8 NPT

Overfill Disconnect Procedure

- 1) Once shut-off has occurred, close the fill nozzle immediately.
- 2) Turn off the pumping system.
- 3) Slowly release one arm of the quick coupler. This will allow product between nozzle and valve to drain. (wait a minimum of (1) minute for product to drain).
- 4) Completely uncouple and remove the nozzle after the line has drained.

Warning: Attempting to disconnect the coupler from the tight fill adaptor with pressure in the hose will result in a product spill.

3" 9095A INSTALLATION INSTRUCTIONS

1. Attach warning tag at fill point, with supplied cable tie, in location visible to operator.
2. Remove the valve from the box and remove all packaging material. Check the valve for any shipping damage. Remove the adaptor and nipple from the valve. Check for freedom of plunger movement by securing float, turning unit upside-down, and looking through the body opening at the plunger. The plunger should slide freely to contact the seal surface of the body and drop back down into the dashpot when turned to the upright position. Set the valve upright and move the floats up and down to insure there is no binding of the parts.
3. Determine the **SHUTOFF HEIGHT** (A) at 90 or 95% full. (See Fig. 1 below & Mfg. tank ullage chart).
4. Find the **SHUTOFF HEIGHT** (A) in table 1. Use Table 1 to determine **RISER PIPE HEIGHT FROM TOP OF THE TANK** (B) and proper **NIPPLE LENGTH** (C) (for applicable stored fluid) required to adapt the unit to your application. Note: A 4" long nipple is provided with the valve.
5. If your existing riser pipe height is different from the **RISER PIPE HEIGHT** (B) required, see step 6. If the **RISER PIPE HEIGHT** (B) is applicable to your tank configuration then go to step 7. **IMPORTANT: THE TANK MUST HAVE A RISER PIPE WITH 6"-8 NPT MALE THREADS TO FIT THE TIGHT FILL ADAPTOR.**
6. Two rules apply when adjusting the riser pipe height; 1) the **RISER PIPE HEIGHT** (B) must not be less than 3 inches and, 2) the **NIPPLE LENGTH** (C) must not be less than 3 inches. For every 1 inch adjustment to the **RISER PIPE HEIGHT** (B), the **NIPPLE LENGTH** (C) must be adjusted 1 inch in the same direction. See example and proceed to step 7.

EXAMPLE: You are installing this overfill prevention valve (with tight fill adaptor) on a gasoline storage tank and you determine your **SHUTOFF HEIGHT** (A) to be 7 inches. According to Table 1, a **SHUTOFF HEIGHT** (A) of 7 inches requires a **RISER PIPE HEIGHT** (B) of 8 inches and a 4 inch long **NIPPLE** (C), (provided). If your tank has a 10 inch **RISER PIPE HEIGHT** (B), (instead of 8 inches), you need to add 2 more inches to the required **NIPPLE LENGTH** (C) in order to maintain the proper shutoff height.

7. Use care with floats and linkage during installation. Apply a non-hardening gasoline resistant sealant sparingly to all male threads. Attach the drop tube to the bottom of the valve. Assemble piping and install valve in the tank to distance determined in steps above.

Caution: Excessive use of thread sealant may cause the valve to function improperly, application of thread sealant should be to male threaded members of the system only (to reduce the possibility of sealant being forced inside the system).

FIGURE 1

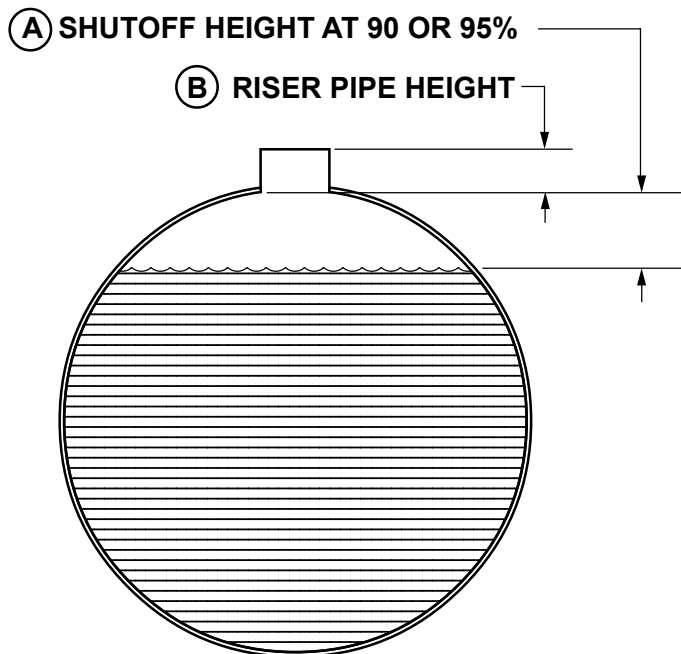

TABLE 1

(A) Shutoff Height	(B) Riser Pipe Height		(C) Nipple Length	
Note: All lengths are inches.	Gasoline	Diesel	Gasoline	Diesel
2"	13"	13.25"	4"	4"
3"	12"	12.25"	4"	4"
4"	11"	11.25"	4"	4"
5"	10"	10.25"	4"	4"
6"	9"	9.25"	4"	4"
7"	8"	8.25"	4"	4"
8"	6"	6.25"	3"	3"
9"	5"	5.25"	3"	3"
10"	5"	5.25"	4"	4"
11"	3"	3.25"	3"	3"
12"	3"	3.25"	4"	4"
13"	3"	3.25"	5"	5"
14"	3"	3.25"	6"	6"
15"	3"	3.25"	7"	7"
16"	3"	3.25"	8"	8"
17"	3"	3.25"	9"	9"
18"	3"	3.25"	10"	10"
19"	3"	3.25"	11"	11"
20"	3"	3.25"	12"	12"
21"	3"	3.25"	13"	13"
22"	3"	3.25"	14"	14"
23"	3"	3.25"	15"	15"
24"	3"	3.25"	16"	16"
25"	3"	3.25"	17"	17"