



OPW Installation and Maintenance Instructions

OPW 1-2100 Series Thread-On Grade Level Spill Containers

IMPORTANT: Please read these warnings and use the assembly instructions completely and carefully before starting. Failure to do so may cause product failure, or result in environmental contamination due to liquid leakage into the soil, creating hazardous spill conditions.

IMPORTANT: The OPW 1-2100 Spill Container is pre-assembled for your convenience and ease of installation. Check to make sure the unit is intact and undamaged and all parts have been supplied. Never substitute parts for those supplied. Doing so may cause product failure.

WARNING-DANGER: Using electrically operated equipment near gasoline or gasoline vapors may result in a fire or explosion, causing personal injury and property damage. Be sure that the working area is free from such hazards, and always use proper precautions.

NOTE: At all times when product is in the storage tank keep the riser pipe capped, so the vapors cannot escape into the environment.

Notice: OPW products must be used in compliance with applicable federal, state, and local laws and regulations. Product selection should be based on physical specifications and limitations and compatibility with the environment and material to be handled. All illustrations and specifications in this literature are based on the latest production information available at the time of publication. Prices, materials, and specification are subject to change at any time, and models may be discontinued at any time, in either case, without notice or obligation.

Standard Product Warranty

OPW warrants that products sold by it are free from defects in materials and workmanship for a period of one year from the date of manufacture by OPW (ECO products two years from date of manufacture.) Proof of purchase may be required. As the exclusive remedy under this limited warranty, OPW, will at its sole discretion, repair, replace, or issue credit for future orders for any product that may prove defective within the one year date of manufacture period (repairs, replacements, or credits may be subject to prorated warranty for remainder of the original warranty period, complete proper warranty claim

documentation required.) This warranty shall not apply to any product that has been altered in any way, which has been repaired by any party other than a service representative authorized by OPW, or when failure is due to misuse, or improper installation or maintenance. OPW shall have no liability whatsoever for special, incidental or consequential damages to any party, and shall have no liability for the cost of labor, freight, excavation, clean up, downtime, removal, reinstallation, loss of profit, or any other cost or charges.

For any product certified to California 2001 standards, OPW warrants that product sold by it are free from defects in material and workmanship for a period of one year from date of manufacture or one year from date of registration of installation not to exceed 15 months from date of manufacture by OPW.

THIS WARRANTY IS IN LIEU OF ALL OTHER WARRANTIES, EXPRESS OR IMPLIED, AND SPECIFICALLY THE WARRANTIES OF MERCHANTABILITY AND FITNESS FOR A PARTICULAR PURPOSE. THERE ARE NO WARRANTIES, WHICH EXTEND BEYOND THE DESCRIPTION ON THE FACE HEREOF.

In California it is prohibit to use spill container drain valves on spill containers that are exclusively used for vapor return risers. Install only 1-2100 Series Thread-On spill containers models equipped with a drain plug.

1-2100 Series Performance Specifications:

This Spill Container drain valve has been manufactured and tested to the following California specifications: Leak Rate to be less than or equal to 0.17 CFH @ 2.0 " W.C.

Torques Specification:

Spill Container 4" NPT, 125 ft-lbs minimum to 250 ft-lbs maximum.

4" Nipple, 4" NPT, 125 ft-lbs minimum to 250 ft-lbs maximum.

Drain Valve clamps, 5/16-18 UN thread, 11.5 ft-lbs minimum to 13.5 ft-lbs maximum.

**OPW NO. 1-2100 SERIES GRADE
LEVEL SPILL CONTAINER
INSTALLATION INSTRUCTIONS:**

Step 1.

Per California SB-989, all metal must be protected from direct contact with the elements. Coat stainless steel band clamps with the following approved coatings. OPW SL-1100, 3M Underseal 08883 or Polyguard Mastic CA-9. Only the threaded hardware needs to be coated in the field.

Step 2: (See Figure 1 & 2)

Set riser pipe. "L" is the distance between the top of the riser pipe and finish grade.

Model Series	"L" Dimension
1-2100, 5 Gallon	L=15" (38cm)
1-2100E, 7.5 Gallon (Deep Bellows Model)	L=21" (53cm)
1-2115, 15 Gallon	L=20" (51cm)

Note:

For Cast Iron base, subtract 1-1/2" from Dimension "L".

If using OPW FSA-400, add 3-1/4" to Dimension "L".

If using OPW FSA-400-S, add 1-3/4" to Dimension "L".

NOTE: FSA-400-S will only work with Cast Iron Base.

Step 3:

Deburr and thoroughly clean riser pipe. Apply pipe dope to riser threads. Pipe dope to be a non-hardening, gasoline resistant pipe thread seal compound.

Step 4:

Install OPW FSA-400 Face Seal Adapter onto riser using the OPW 61SA-TOOL. Torque to 125 ft-lbs min. to 250 ft-lbs max. (4" NPT). Apply pipe dope to FSA-400. Pipe dope to be a non-hardening, gasoline resistant pipe thread seal compound.

Step 5:

Install spill container by rotating the mounting ring until hand tight.

NOTE: Do not attempt to completely tighten the container by using the mounting ring

Step 6:

Finish tightening the spill container with the OPW 61SA-TOOL. Torque to 125 ft-lbs min. to 250 ft. Lbs. max. (4" NPT)

Step 7: (See Figure 2)

Apply pipe dope to nipple and install. Pipe dope to be a non-hardening, gasoline resistant pipe thread seal compound. Use only factory made nipples. Nipples must be cut square and deburred. Torque to 125 ft-lbs min. to 250 ft-lbs max. (4" NPT). Torque value is

based on rotation at the center of pipe. For standard cover models install adaptor and dust cap. For sealable cover (1SC) models, install a standard 4" pipe cap to support adjustment system. (Adaptor and dust cap must be installed in sealable cover (SC) models after concrete has dried.

Note: Nipple length is determined by measuring from the bottom of the threaded portion of the base to the bottom of the cover. Then subtract 2" for clearance, height of adaptor and height of cap. Range of nipple lengths that can be used in all of the OPW spill containers: 4" minimum to 14" maximum.

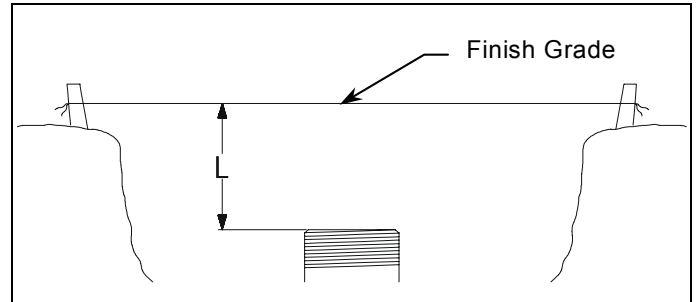

Figure 1

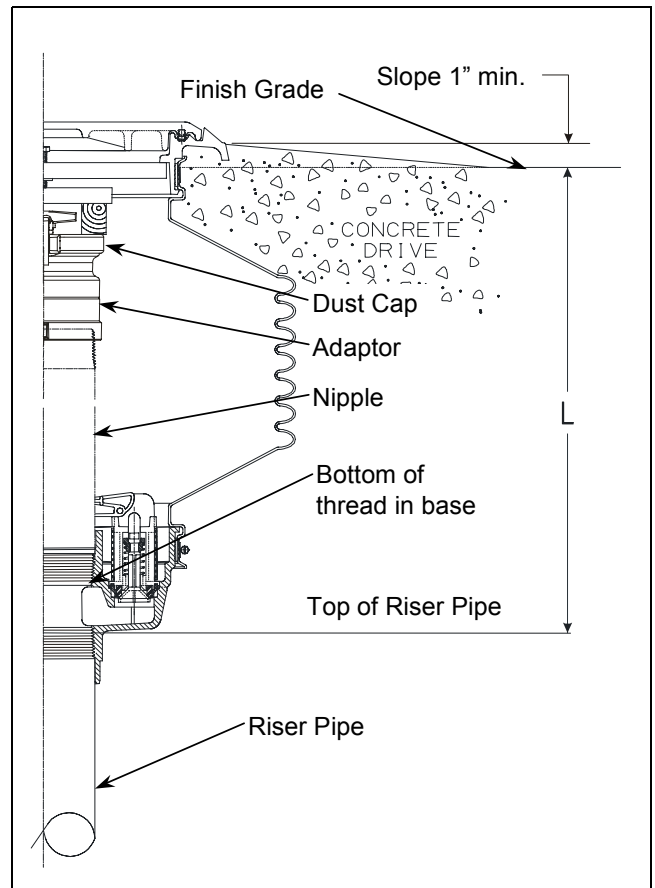

Figure 2

Step 8: (See Figure 3 & 4)

Install adjusting system beneath tabs on mounting ring. See Figure 3 for standard cover models. See Figure 4 for sealable cover models. Add shims as needed and adjust with screw. (Shims must be cut to size for sealable cover models.) The height can be increased up to 1" (2.5cm).

Note: The adjustment should not be more than 1" from the initial length of the unit.

Step 9:

Upon preliminary installation perform the California Test Procedures TP-201.1C or equivalent. Their Test Procedures will check the seals between the drain valve, nipple and rotatable adapter. To test the spill containers base and bellows fill the container with water. A drop in the water level of 1/16" or greater after one hour means that a leak exists. To determine where the leak is, look for a steady stream of bubbles coming from one of the joints or water leaking on the outside of the bucket. **NOTE:** Do not drain the water into the UST after the test is complete. Water must be disposed of per local requirements for hazardous waste. If the leak cannot be corrected the spill container should be replaced with another.

Step 10: (See Figure 2)

Before pouring concrete, place plastic over the cover and mounting ring protecting them from concrete splash. Double check that the unit is level and at proper grade height. Pour concrete per figure 2. Ramp or dome the concrete away from the mounting ring. There should be a minimum of 1" slope to finish grade. The concrete surface should start at the bottom edge of the watershed slots and tapered down to grade level.

NOTE: Do not stand on spill container before concrete sets up.

Remove plastic from cover after concrete has dried. Remove adjustment system. Adaptor and tight fill cap can now be installed in sealable cover models. Re-test the spill containers for leaks as described in step 9, after the concrete has set up.

Operation and Maintenance:

Annually: Inspect and clean the interior of the spill container and drain valve screen. Remove accumulated dirt and grit. Test the drain valve using CARB procedure TP-201.1C or TP-201.1D. If the drain valve passes testing no further maintenances required. If the drain valve fail testing, remove the valve, soak in water and use high-pressure air, if needed, to clean. Reinstall the drain valve to its proper position and test the valve with CARB procedure TP-201.1C or TP-201.1D. If problems persist, replace the drain valve with P/N 1DK-2100-EVR (specified torque 11.5 ft-lbs min to 13.5 ft-lbs max, 5/16-18 UN thread). The sealable cover (1SC)

adjustment nut is set at the factory, but due to environmental conditions it may be necessary to adjust it to either improve sealing or ease cover removal.

Important: Leave these instructions with Station Operator.

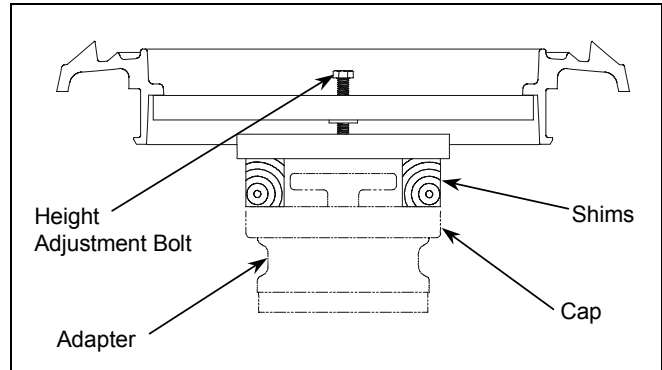

Figure 3 – Standard Cover Model Height Adjustment

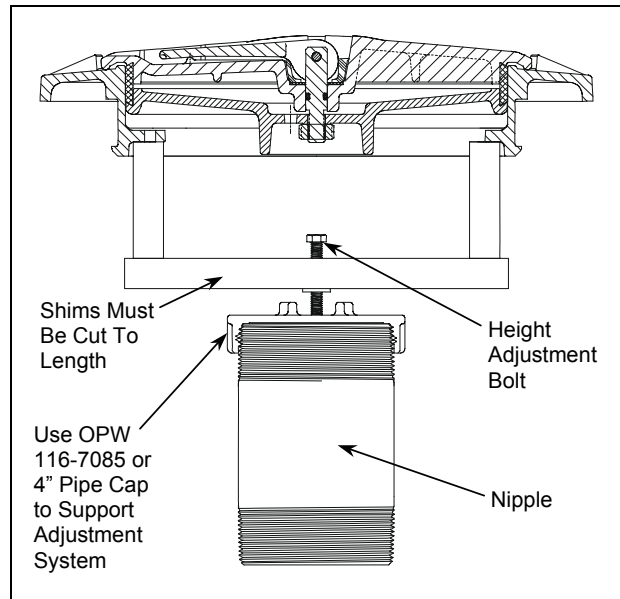

Figure 4 – Sealable Cover Model Height Adjustment



P.O. Box 405003 * Cincinnati, Ohio 45240-5003
1-800-422-2525 Domestically
513-870-3315 Internationally
www.opw-fc.com

Copyright, 2003 - OPW Fueling Components Inc.,
Cincinnati, OH

Printed in U.S.A. p/n H12295PA – 9/03