



POMECO Installation and Maintenance Instructions Multi-Port Spill Containment Manholes

IMPORTANT: Please read these warnings and use the assembly instructions completely and carefully before starting. Failure to do so may cause product failure, or result in environmental contamination due to liquid leakage into the soil, creating hazardous spill conditions.

IMPORTANT: The POMECO Spill Container is pre-assembled for your convenience and ease of installation. Check to make sure the unit is intact and undamaged and all parts have been supplied. Never substitute parts for those supplied. Doing so may cause product failure.

WARNING-DANGER: Using electrically operated equipment near gasoline or gasoline vapors may result in a fire or explosion, causing personal injury and property damage. Be sure that the working area is free from such hazards, and always use proper precautions.

NOTE: At all times when product is in the storage tank keep the riser pipe capped, so the vapors cannot escape into the environment.

Notice: OPW products must be used in compliance with applicable federal, state, and local laws and regulations. Product selection should be based on physical specifications and limitations and compatibility with the environment and material to be handled. All illustrations and specifications in this literature are based on the latest production information available at the time of publication. Prices, materials, and specification are subject to change at any time, and models may be discontinued at any time, in either case, without notice or obligation.

Standard Product Warranty

OPW warrants that products sold by it are free from defects in materials and workmanship for a period of one year from the date of manufacture by OPW (ECO products may be required. As the exclusive remedy under this limited warranty, OPW, will at its sole discretion, repair, replace, or issue credit for future orders for any product that may prove defective within the one year date of manufacture period (repairs, replacements, or credits may be subject to prorated warranty for remainder of the original warranty period, complete proper warranty claim documentation required.) This warranty shall not apply to any product that has been altered in any way, which has been repaired by any party other than a service representative authorized by OPW, or when failure is due to misuse, or improper installation or maintenance. OPW shall have no liability whatsoever for special, incidental or

consequential damages to any party, and shall have no liability for the cost of labor, freight, excavation, clean up, downtime, removal, reinstallation, loss of profit, or any other cost or charges.

For any product certified to California 2001 standards, OPW warrants that product sold by it are free from defects in material and workmanship for a period of one year from date of manufacture or one year from date of registration of installation not to exceed 15 months from date of manufacture by OPW.

THIS WARRANTY IS IN LIEU OF ALL OTHER WARRANTIES, EXPRESS OR IMPLIED, AND SPECIFICALLY THE WARRANTIES OF MERCHANTABILITY AND FITNESS FOR A PARTICULAR PURPOSE. THERE ARE NO WARRANTIES, WHICH EXTEND BEYOND THE DESCRIPTION ON THE FACE HEREOF.

In California it is prohibit to use spill container drain valves on spill containers that are exclusively used for vapor return risers. Install only 1-2100 Series Thread-On spill containers models equipped with drain plug P/N 1DP-2100.

Multi-Port Performance Specifications:

This Spill Container drain valve has been manufactured and tested to the following California specifications: Leak Rate at 0.17 CFH @ 2.0 " W.C.

Torques Specification:

Spill Container 4" NPT, 125 ft-lbs minimum to 250 ft-lbs maximum.

4" Nipple, 4" NPT, 125 ft-lbs minimum to 250 ft-lbs maximum.

Drain Valve clamps, 5/16-18 UN thread, 11.5 ft-lbs minimum to 13.5 ft-lbs maximum.

Mounting Ring Stud, 5/16-18 UN thread, 15 ft-lbs minimum to 20 ft-lbs maximum.

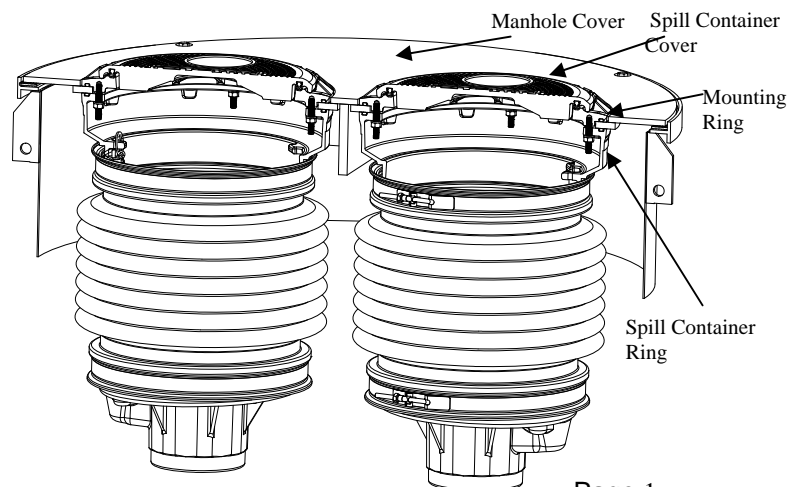

POMECO Multi-Port Spill Container Manhole Installation Instructions

1. Mark off finish grade. (See Figure 1.)

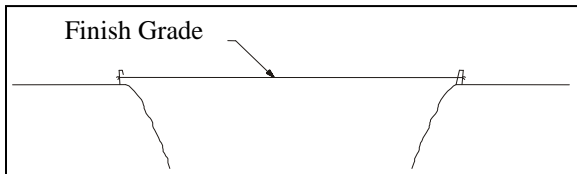

Figure 1

2. Set multi-port manhole assembly (skirt, ring, and cover) to the final grade position. (See Figure 2.)

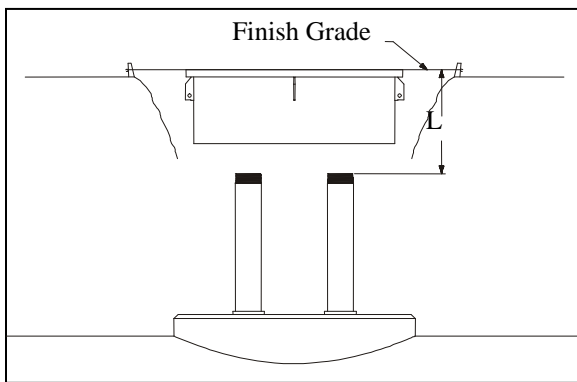

Figure 2

Note: It is strongly recommended that POMECO covers be installed with the following minimum clearances. Sheet metal skirts should have adequate clearance between the tank sump riser sidewall and or the sump top hat. A minimum of one and a half inches clearance on all sides is recommended between the POMECO skirt and the tank sump wall or the sump top hat wall. A minimum of two inches clearance is recommended between the bottom of the POMECO skirt and the horizontal surface of the tank sump or sump top hat. These clearances are recommended to allow adequate water migration away from the sumps. Great care should be used to maintain the recommended clearances when setting the rings and pouring the concrete. (See Figure 3.)

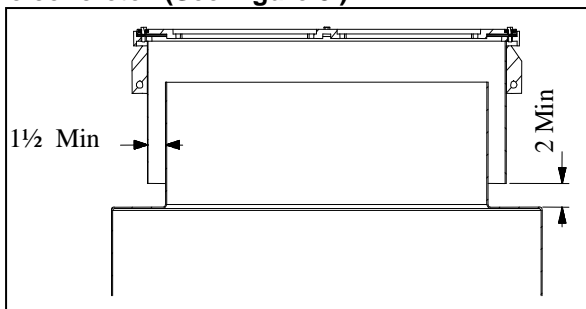

Figure 3

3. Remove the cover and measure the distance from the top of the tanks to the final grade.
4. Cut the riser(s) from the underground tank so that both the fill and vapor risers are set below the final grade. Use the dimensions below:

| Spill Container | Inches below grade (L) |
|-------------------------|------------------------|
| 5 Gal. Cast Iron Base | 18 1/2" |
| 5 Gal. Composite Base | 19 5/8" |
| 7.5 Gal. Cast Iron Base | 22 1/2" |
| 7.5 Gal. Composite Base | 23 5/8" |
| 15 Gal Cast Iron Base | 22 1/2" |
| 15 Gal. Composite Base | 23 5/8" |

Note: Add an extra 3-1/4" when using an OPW FSA-400 Face Seal Adaptor, recommended for Composite Base. Add an extra 1 3/4" when using the FSA-400-S Face Seal Adaptor, recommended for Cast Iron Base. (See Figure 2.)

5. Deburr and thoroughly clean riser pipe(s).
6. Apply pipe dope to riser(s). The pipe dope is to be a non-hardening, gasoline resistant, pipe thread seal compound.
7. Install OPW FSA-400 Face Seal Adapter onto riser. (Recommend Torque, 4" NPT, 125 ft-lbs min. to 250 ft-lbs max.). Apply pipe dope to FSA-400. The pipe dope is to be a non-hardening, gasoline resistant, pipe thread seal compound. This is optional for spill containers that are on the vapor lines.
8. Thread on spill containers
9. Using the 61SA-TOOL, tighten the spill container(s) onto the riser(s) with a minimum torque of 125 ft.-lbs. and a maximum torque of 250 ft.-lbs.

Note: Do NOT attempt to completely tighten the containment bucket by using the containment bucket mounting ring at the top of the bucket.

10. Inspect the containment bucket O-Rings and Mounting Ring O-Rings for damage. Replace the gasket(s) if they are damaged.
11. Install Optional Multi-Port Water Shroud (MPWS). See separate instructions.
12. Remove Spill Container Cover and Spill Container Mounting ring from Manhole Cover.
13. Replace the multi-port cover, centering the riser(s) as close as possible in the containment openings. Be very careful not to move or damage the O-Rings.
14. Remove lock washers and nuts from the studded mounting ring.

15. Place the mounting ring over the containment buckets and rotate the mounting ring until the studs are aligned with the bucket ring holes. (See Figure 4.)

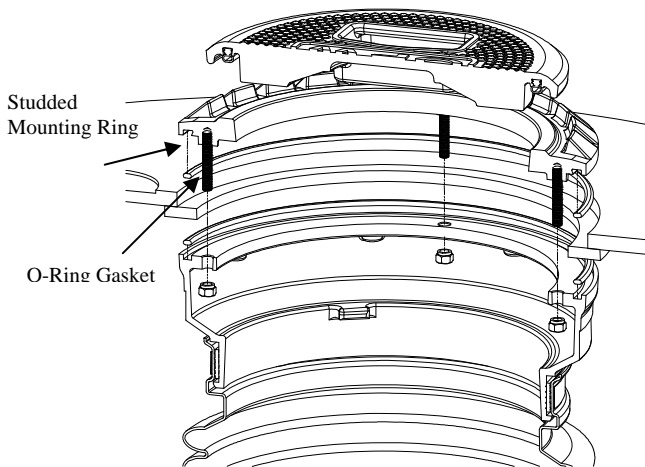

Figure 4

16. Thread nut and lock washer onto studded mounting ring. Tighten the mounting ring retaining bolts until the containment bucket o-rings makes contact with the multi-port cover. Then, in a crossing pattern, torque the bolts down between 15 to 20 ft.-lbs. 6 Point Ratcheting box wrench is recommended (See Figure 5.)

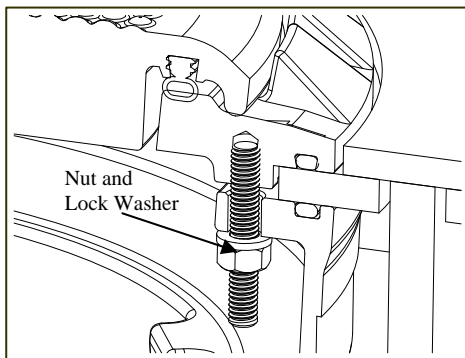

Figure 5

17. Install the spill bucket covers.
18. (Optional): Install the product identification disc on the spill bucket cover and multi-port cover in the I.D. disc recess.
19. Cover the multi-port perimeter ring and cover with plastic to prevent concrete from settling in the drainage areas.

20. It is required that the perimeter ring and skirt assembly, and the multi-port cover be set as an assembled unit, with the bolts engaged. Failure to engage the bolts may result in the distortion of the ring and improper fit of the ring to cover after the concrete is poured.
21. When pouring the concrete, hand shovel or trowel the concrete around the multi-port assembly to prevent the unit from moving or shifting, which can cause alignment problems and future maintenance problems.

Note: Do not stand on the multi-port before the concrete has set up.

22. It is recommended that the paved contours around POMECA covers be adequately sloped to direct water flow away from the cover, and directing water runoff from adjacent areas away from POMECA covers. (See Figure 7.)

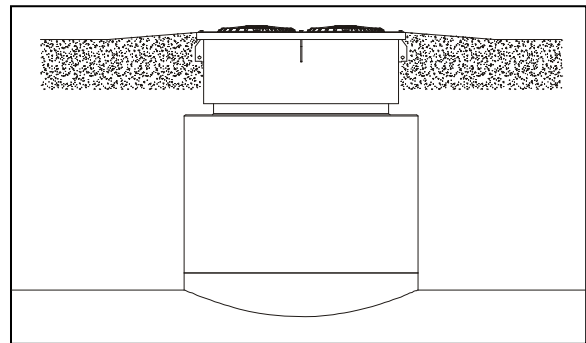

Figure 7

23. Remove the plastic after the concrete has set up.
24. After installation is complete, water test the multi-port fixture. The recommended water test procedures include:
 - a) Spraying water on cover(s) for 5 to 10 minutes, using a commonly available watering device such as a lawn sprinkler.
 - b) Standing water test, not to exceed ½" in water depth for a period of 5 to 10 minutes.

Note: The containment bucket consists of three components cast iron ring, bellows, and bucket bottom. These parts are held together with stainless steel retaining bands.

DO NOT loosen the stainless steel retaining bands securing the bellows to the containment bucket top ring or the containment bucket bottom. Loosening the retaining bands voids any and all warranties on this product.

Warning:

If the cover is removed, for any reason, follow the Service and Maintenance instruction as noted. Always inspect and replace damaged o-rings and install new o-rings. Never reuse

damaged o-rings as it may result in an improper seal.

Operation and Maintenance:

After each fuel delivery, the operator must remove any standing fuel from the container. Fuel can be removed by actuating the drain valve or with a gasoline absorbing disposable towel. Annually: Inspect and clean the interior of the spill container and drain valve screen. Remove accumulated dirt and grit. If the drain valve screen becomes clogged, remove the valve, soak in water and use high-pressure air to clean. Reinstall the drain valve to its proper position and test the valve per the appropriate TP201-1C Test Procedure. If problems persist, replace the drain valve with P/N 1DK-2100-EVR (specified torque 11.5 ft-lbs min to 13.5 ft-lbs max, 5/16-18 UN thread). The sealable cover (1SC) adjustment nut is set at the factory, but due to environmental conditions it may be necessary to adjust it to either improve sealing or ease cover removal.

Testing Spill Containers

Use TP201-1C or TP201-1D Test Procedures. Their Test Procedures will check the seals between the drain valve, nipple and rotatable adapter. To test the spill containers base and bellows fill the

container with water. A drop in the water level of 1/16" or greater after one hour means that a leak exists. To determine where the leak is, look for a steady stream of bubbles coming from one of the joints or water leaking on the outside of the bucket. **NOTE:** Do not drain the water into the UST after the test is complete. Water must be disposed of per local requirements for hazardous waste. If the leak cannot be corrected the spill container should be replaced with another.

POMECO recommends periodic inspection of covers and seals as a part of the regularly scheduled maintenance program. If any of the seals are damaged they should be replaced. Only qualified, competent, well-trained technicians should perform maintenance.

Note: Common sense and good judgment should always be exercised. The contractor's understanding of all related site conditions prior to starting the project is essential. If the contractor does not have a clear understanding of the required work and site conditions, the contractor is advised to seek clarification prior to starting any portion of the project.

Important: Leave these instructions with Station Operator as per CARB Requirements



Marketing Agent for POMECO by OPW, Inc.
Copyright, 2002 - OPW Fueling Components Inc., Cincinnati, OH
Printed in U.S.A. p/n H15225PA – 05/05