

# Diaphragm Pumps

## Transfer Pumps

### Quick Reference

4

Body / Diaphragm Description	Part Number	Ratio	Max. Air psi (bar)	Typical Application	Free Flow Rate gpm (lpm)	Max. Rec CPM
<b>307 3/8" Diaphragm Pump</b> Acetal / Hytrel	D31255	1:1	100 (7)	OT, WA, WWS*	7 (31.8)	330
<b>515/716 3/4" Diaphragm Pump</b> Aluminum / Buna N	241906	1:1	100 (7)	OT, OE, WA, WWS	16 (60.6)	400
Acetal / Buna Dual Inlet	243669	1:1	100 (7)	50/50 WWS, WA	16 (60.6)	400
<b>1040 1" Diaphragm Pump</b> Aluminum / Hytrel	D73525	1:1	120 (8.3)	OT, WA, OE	40 (151.4)	276
Aluminum / Hytrel (UL)	236265	1:1	120 (8.3)	OE, FT**, WA	40 (151.4)	276
Aluminum / Hytrel (UL)	236267	1:1	50 (3.4)	FD**	20 (75.7)	130
<b>1590 1-1/2" Diaphragm Pump</b> Aluminum / Hytrel	DB3525	1:1	120 (8.3)	OT, OE, WA	90 (340.6)	200
<b>2150 2" Diaphragm Pump</b> Aluminum / Hytrel	DF3525	1:1	120 (8.3)	OT, OE, WA	150 (567)	145
<b>3275 3" Diaphragm Pump</b> Aluminum / Hytrel	DK3525	1:1	120 (8.3)	OT, OE, WA	275 (1,041)	135

Note: See page 149 for other diaphragm pump packages

\* See page 139 for windshield wash solution 307 Package 237160.

\*\* For use with leaded fuel

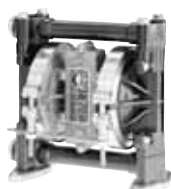

D31255



241906



236265



DB3525



DF3525

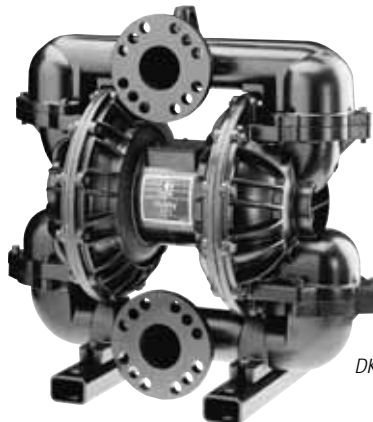

DK3525

Mascott Equipment Co

Portland

Seattle

Pasco

(800) 452-5019

(800) 481-7311

(888) 450-7867

### Key

- OT = Oil Transfer
- OE = Oil Evacuation
- WA = Water, Anti-freeze
- FD = Fuel Dispense (with 50 psi relief valve)
- FT = Fuel Transfer
- WWS = Windshield Wash Solution

Air Consumption SCFM	Air Inlet NPT	Fluid Inlet/ Outlet NPT	Air Motor Kit	Kits (Seats Balls, Diaphragms)	Diaphragm Kit	Manual No.
7	1/4	3/8	239952	D03255	D03005	308553
28	1/4	3/4	241657	D05277	D05007	308573
28	1/4	3/4	241657	D05277	D05007	
40	1/2	1	236273	D07525	D07005	308326
40	1/2	1	236273	D07525	D07005	and
20	1/2	1	236273	D07525	D07005	308479
90	1/2	1-1/2	236273	D0B525	D0B005	308441
175	1/2	2	236273	D0F525	D0F005	308368
325	3/4	3	238765	D0K525	D0K005	308639

4

## Mounting Accessories

Pump	307	515/716	1040	1590	2150	3275
Air Line Filter	110146	110146	106148	106149	106150	106150
Air Regulator & Gauge	110147	110147	244844	202858	206199	207651
Air Quick-Connect Coupler	208536 1/4 npt (f)	208536 1/4 npt (f)	110199 1/2 npt (f)	110199 1/2 npt (f)	110199 1/2 npt (f)	N/A
Air Quick-Connect Nipple	169970 1/4 npt (m)	169970 1/4 npt (m)	110196 1/2 npt (m)	110196 1/2 npt (f)	110196 1/2 npt (f)	N/A
Bleed Type Air Valve	110223	110223	110224	110225	110225	110226
Wall Bracket	224835	224835	189233	N/A	N/A	N/A
Thermal Relief Kit	238899	238428	238428	N/A	N/A	N/A
Thermal Relief Valves 150 psi (10.3 bar)	113497 al/bn 112119 ss/tf	113497 al/bn 112119 ss/tf	113497 al/bn 112119 ss/tf	113497 al/bn 112119 ss/tf	113497 al/bn 112119 ss/tf	113497 al/bn 112119 ss/tf
Grounding Wire and Clamp	222011	222011	222011	222011	222011	222011
Suction Hose Kit	236054	236054	236054	N/A	N/A	N/A
Flange Adapter Kit	N/A	N/A	N/A	N/A	N/A	N/A
Dual Inlet Manifold	N/A	*	685984**	N/A	N/A	N/A
Instruction Manual	308553	308573 and 308981	308326 & 308479	308441	308368	308639

\*243669 comes with dual inlet, see page 58

\*\*Dual inlet must be ordered separately for 685984